

# **PHILIPPINE BIDDING DOCUMENTS**

**“Construction of Underground Powerlines (Supply of Materials, Labor and Services) Phase 3 (Lot 1) and Phase 4 (Lot 2) in Brgy. Esteves, Casiguran, Aurora”**

**NEA-PB No. 2025-06**





# TABLE OF CONTENTS

<b>GLOSSARY OF .....</b>	<b>4</b>
<b>TERMS, ABBREVIATIONS, AND ACRONYMS .....</b>	<b>4</b>
<b>SECTION I. INVITATION TO BID .....</b>	<b>7</b>
<b>SECTION II. INSTRUCTIONS TO BIDDERS.....</b>	<b>10</b>
1.    Scope of Bid.....	11
2.    Funding Information .....	11
3.    Bidding Requirements.....	11
4.    Corrupt, Fraudulent, Collusive, Coercive, and Obstructive Practices .....	11
5.    Eligible Bidders.....	12
6.    Origin of Associated Goods .....	12
7.    Subcontracts .....	12
8.    Pre-Bid Conference .....	12
9.    Clarification and Amendment of Bidding Documents .....	12
10.   Documents Comprising the Bid: Eligibility and Technical Components.....	12
11.   Documents Comprising the Bid: Financial Component .....	13
12.   Alternative Bids .....	13
13.   Bid Prices .....	13
14.   Bid and Payment Currencies .....	14
15.   Bid Security.....	14
16.   Sealing and Marking of Bids.....	14
17.   Deadline for Submission of Bids .....	14
18.   Opening and Preliminary Examination of Bids .....	14
19.   Detailed Evaluation and Comparison of Bids.....	15
20.   Post Qualification.....	15
21.   Signing of the Contract .....	15
<b>SECTION III. BID DATA SHEET .....</b>	<b>16</b>
<b>SECTION IV. GENERAL CONDITIONS OF CONTRACT .....</b>	<b>19</b>
1.    Scope of Contract.....	20
2.    Sectional Completion of Works .....	20
3.    Possession of Site.....	20
4.    The Contractor’s Obligations.....	20
5.    Performance Security .....	21
6.    Site Investigation Reports .....	21

7.	Warranty.....	21
8.	Liability of the Contractor.....	21
9.	Termination for Other Causes.....	21
10.	Dayworks .....	22
11.	Program of Work.....	22
12.	Instructions, Inspections and Audits .....	22
13.	Advance Payment.....	22
14.	Progress Payments .....	22
15.	Operating and Maintenance Manuals.....	22
<b>SECTION V. SPECIAL CONDITIONS OF CONTRACT.....</b>		<b>24</b>
<b>SECTION VI. SPECIFICATIONS .....</b>		<b>26</b>
<b>SECTION VII. DRAWINGS.....</b>		<b>46</b>
<b>SECTION VIII. BILL OF QUANTITIES.....</b>		<b>54</b>
<b>SECTION IX. CHECKLIST OF TECHNICAL AND FINANCIAL DOCUMENTS .....</b>		<b>82</b>

# ***Glossary of Terms, Abbreviations, and Acronyms***

**ABC** – Approved Budget for the Contract.

**ARCC** – Allowable Range of Contract Cost.

**BAC** – Bids and Awards Committee.

**Bid** – A signed offer or proposal to undertake a contract submitted by a bidder in response to and in consonance with the requirements of the bidding documents. Also referred to as *Proposal* and *Tender*. (2016 revised IRR, Section 5[c])

**Bidder** – Refers to a contractor, manufacturer, supplier, distributor and/or consultant who submits a bid in response to the requirements of the Bidding Documents. (2016 revised IRR, Section 5[d])

**Bidding Documents** – The documents issued by the Procuring Entity as the bases for bids, furnishing all information necessary for a prospective bidder to prepare a bid for the Goods, Infrastructure Projects, and/or Consulting Services required by the Procuring Entity. (2016 revised IRR, Section 5[e])

**BIR** – Bureau of Internal Revenue.

**BSP** – Bangko Sentral ng Pilipinas.

**CDA** – Cooperative Development Authority.

**Consulting Services** – Refer to services for Infrastructure Projects and other types of projects or activities of the GOP requiring adequate external technical and professional expertise that are beyond the capability and/or capacity of the GOP to undertake such as, but not limited to: (i) advisory and review services; (ii) pre-investment or feasibility studies; (iii) design; (iv) construction supervision; (v) management and related services; and (vi) other technical services or special studies. (2016 revised IRR, Section 5[i])

**Contract** – Refers to the agreement entered into between the Procuring Entity and the Supplier or Manufacturer or Distributor or Service Provider for procurement of Goods and Services; Contractor for Procurement of Infrastructure Projects; or Consultant or Consulting Firm for Procurement of Consulting Services; as the case may be, as recorded in the Contract Form signed by the parties, including all attachments and appendices thereto and all documents incorporated by reference therein.

**Contractor** – is a natural or juridical entity whose proposal was accepted by the Procuring Entity and to whom the Contract to execute the Work was awarded. Contractor as used in these Bidding Documents may likewise refer to a supplier, distributor, manufacturer, or consultant.

**CPI** – Consumer Price Index.

**DOLE** – Department of Labor and Employment.

**DTI** – Department of Trade and Industry.

**Foreign-funded Procurement or Foreign-Assisted Project** – Refers to procurement whose funding source is from a foreign government, foreign or international financing institution as specified in the Treaty or International or Executive Agreement. (2016 revised IRR, Section 5[b]).

**GFI** – Government Financial Institution.

**GOCC** – Government-owned and/or –controlled corporation.

**Goods** – Refer to all items, supplies, materials and general support services, except Consulting Services and Infrastructure Projects, which may be needed in the transaction of public businesses or in the pursuit of any government undertaking, project or activity, whether in the nature of equipment, furniture, stationery, materials for construction, or personal property of any kind, including non-personal or contractual services such as the repair and maintenance of equipment and furniture, as well as trucking, hauling, janitorial, security, and related or analogous services, as well as procurement of materials and supplies provided by the Procuring Entity for such services. The term “related” or “analogous services” shall include, but is not limited to, lease or purchase of office space, media advertisements, health maintenance services, and other services essential to the operation of the Procuring Entity. (2016 revised IRR, Section 5[r])

**GOP** – Government of the Philippines.

**Infrastructure Projects** – Include the construction, improvement, rehabilitation, demolition, repair, restoration or maintenance of roads and bridges, railways, airports, seaports, communication facilities, civil works components of information technology projects, irrigation, flood control and drainage, water supply, sanitation, sewerage and solid waste management systems, shore protection, energy/power and electrification facilities, national buildings, school buildings, hospital buildings, and other related construction projects of the government. Also referred to as *civil works or works*. (2016 revised IRR, Section 5[u])

**LGUs** – Local Government Units.

**NFCC** – Net Financial Contracting Capacity.

**NGA** – National Government Agency.

**PCAB** – Philippine Contractors Accreditation Board.

**PhilGEPS** - Philippine Government Electronic Procurement System.

**Procurement Project** – refers to a specific or identified procurement covering goods, infrastructure project or consulting services. A Procurement Project shall be described, detailed, and scheduled in the Project Procurement Management Plan prepared by the agency which shall be consolidated in the procuring entity's Annual Procurement Plan. (GPPB Circular No. 06-2019 dated 17 July 2019)

**PSA** – Philippine Statistics Authority.

**SEC** – Securities and Exchange Commission.

**SLCC** – Single Largest Completed Contract.

**UN** – United Nations.



## ***Section I. Invitation to Bid***



## **Invitation to Bid for the Construction of Underground Powerlines (Supply of Materials, Labor and Services) Phase 3 (Lot 1) and Phase 4 (Lot 2) in Barangay Esteves, Casiguran, Aurora**

1. The National Electrification Administration, through the 2024 General Appropriation Act (GAA) No. 11975 for Locally-Funded Projects intends to apply the sum of Php101,941,747.00 (Lot 1) and Php179,611,650.00 (Lot 2) to payments under the contract for each lot for the Construction of Underground Powerlines Phase 3 and Phase 4 in Barangay Esteves, Casiguran, Aurora being the Approved Budget for the Contract (ABC). Bids received in excess of the ABC for each lot shall be automatically rejected at bid opening. A prospective bidder may participate in and submit a bid for both lots.
2. The *National Electrification Administration* now invites bids for the above Procurement Project. Completion of the Works is required within 270 calendar days upon receipt of Notice to Proceed. Bidders should have completed a Single Largest Completed Contract (SLCC) that is similar to the contract to be bid, and whose value, must be at least fifty percent (50%) of the ABC. The description of an eligible bidder is contained in the Bidding Documents, particularly, in Section II (Instructions to Bidders).
3. Bidding will be conducted through open competitive bidding procedures using non-discretionary "*pass/fail*" criterion as specified in the 2016 revised Implementing Rules and Regulations (IRR) of Republic Act (RA) No. 9184.
4. Interested bidders may obtain further information from the National Electrification Administration and inspect the Bidding Documents at the address given below from *Monday to Friday at 8:00 am to 5:00 pm*.
5. A complete set of Bidding Documents may be acquired by interested bidders on February 7, 2025 to March 3, 2025 from the given address and website/s below, *and upon payment of the applicable fee for the Bidding Documents, pursuant to the latest Guidelines issued by the GPPB, in the amount of Php50,000.00 for each lot*. Interested bidders may bid for both lots. The Procuring Entity will require the bidder to present its proof of payment for the fees.
6. The *National Electrification Administration* will hold a Pre-Bid Conference<sup>1</sup> on February 17, 2025, 9:00 AM at the Cultural Affairs Room (CAR), 2<sup>nd</sup> Floor, NEA Bldg., NIA Road, Diliman, Quezon City which shall be open to prospective bidders.
7. Bids must be duly received by the BAC Secretariat through manual submission at the office address as indicated below, on or before 9:00 AM, March 3, 2025. Late bids shall *not be accepted*.



8. All bids must be accompanied by a bid security in any of the acceptable forms and in the amount stated in **ITB** Clause 16.
9. Bid opening shall be at 9:15 AM, March 3, 2025 at the Cultural Affairs Room (CAR), 2<sup>nd</sup> Floor, NEA Bldg., NIA Road, Diliman, Quezon City Bids will be opened in the presence of the bidders' representatives who choose to attend the activity.
10. The *National Electrification Administration* reserves the right to reject any and all bids, declare a failure of bidding, or not award the contract at any time prior to contract award in accordance with Sections 35.6 and 41 of the 2016 revised Implementing Rules and Regulations (IRR) of RA No. 9184, without thereby incurring any liability to the affected bidder or bidders.
11. For further information, please refer to:

**JULIO H. COLINA**

*SBAC Secretariat*

National Electrification Administration

NEA BAC Office, 3<sup>rd</sup> Floor, NEA Building, #57 NIA Road, Diliman, Quezon City

**[procurement@nea.gov.ph](mailto:procurement@nea.gov.ph)**

Contact number: 8929-19-09 local: 3138

12. You may visit the following websites:

<https://www.nea.gov.ph/ao39/bids-and-notice>

*February 7, 2025*

(Sgd.)

**ERNESTO O. SILVANO, JR.**

*SBAC Chairperson*

## ***Section II. Instructions to Bidders***

## **1. Scope of Bid**

The Procuring Entity, *National Electrification Administration* invites Bids for the Construction of Underground Powerlines (Supply of Materials, Labor and Services) Phase 3 (Lot 1) and Phase 4 (Lot 2) in Brgy. Esteves, Casiguran, Aurora, with Project Identification Number NEA-PB No. 2025-06.

The Procurement Project (referred to herein as “Project”) is for the construction of Works, as described in Section VI (Specifications).

## **2. Funding Information**

2.1. The GOP through the source of funding as indicated below for 2024 in the amount of.

Lot 1 - Php101,941,747.00

Lot 2 - Php179,611,650.00

2.2. The source of funding is:

the General Appropriation Act (GAA) No. 11975 for Locally-Funded Projects

## **3. Bidding Requirements**

The Bidding for the Project shall be governed by all the provisions of RA No. 9184 and its 2016 revised IRR, including its Generic Procurement Manual and associated policies, rules and regulations as the primary source thereof, while the herein clauses shall serve as the secondary source thereof.

Any amendments made to the IRR and other GPPB issuances shall be applicable only to the ongoing posting, advertisement, or invitation to bid by the BAC through the issuance of a supplemental or bid bulletin.

The Bidder, by the act of submitting its Bid, shall be deemed to have inspected the site, determined the general characteristics of the contracted Works and the conditions for this Project, such as: (a) the location and the nature of the work; (b) climatic conditions; (c) transportation facilities; (d) nature and condition of the terrain, geological conditions at the site communication facilities, requirements, location and availability of construction aggregates and other materials, labor, water, electric power and access roads; and ( e) other factors that may affect the cost, duration and execution or implementation of the contract, project, or work and examine all instructions, forms, terms, and project requirements in the Bidding Documents.

## **4. Corrupt, Fraudulent, Collusive, Coercive, and Obstructive Practices**

The Procuring Entity, as well as the Bidders and Contractors, shall observe the highest standard of ethics during the procurement and execution of the contract. They or through an agent shall not engage in corrupt, fraudulent, collusive, coercive, and obstructive practices defined under Annex “I” of the 2016 revised IRR of RA No. 9184 or other integrity violations in competing for the Project.

## 5. Eligible Bidders

- 5.1. Only Bids of Bidders found to be legally, technically, and financially capable will be evaluated.
- 5.2. The Bidder must have an experience of having completed a Single Largest Completed Contract (SLCC) that is similar to this Project, equivalent to at least fifty percent (50%) of the ABC adjusted, if necessary, by the Bidder to current prices using the PSA's CPI, except under conditions provided for in Section 23.4.2.4 of the 2016 revised IRR of RA No. 9184.  
  
A contract is considered to be "similar" to the contract to be bid if it has the major categories of work stated in the **BDS**.
- 5.3. For Foreign-funded Procurement, the Procuring Entity and the foreign government/foreign or international financing institution may agree on another track record requirement, as specified in the Bidding Document prepared for this purpose.
- 5.4. The Bidders shall comply with the eligibility criteria under Section 23.4.2 of the 2016 IRR of RA No. 9184.

## 6. Origin of Associated Goods

There is no restriction on the origin of Goods other than those prohibited by a decision of the UN Security Council taken under Chapter VII of the Charter of the UN.

## 7. Subcontracts

The Procuring Entity has prescribed that:  
**Subcontracting is not allowed.**

## 8. Pre-Bid Conference

The Procuring Entity will hold a pre-bid conference for this Project on the specified date and time and either at its physical address as indicated in paragraph 6 of the **IB**.

## 9. Clarification and Amendment of Bidding Documents

Prospective bidders may request for clarification on and/or interpretation of any part of the Bidding Documents. Such requests must be in writing and received by the Procuring Entity, either at its given address or through electronic mail indicated in the **IB**, at least ten (10) calendar days before the deadline set for the submission and receipt of Bids.

## 10. Documents Comprising the Bid: Eligibility and Technical Components

- 10.1. The first envelope shall contain the eligibility and technical documents of the Bid as specified in **Section IX. Checklist of Technical and Financial Documents**.

- 10.2. If the eligibility requirements or statements, the bids, and all other documents for submission to the BAC are in foreign language other than English, it must be accompanied by a translation in English, which shall be authenticated by the appropriate Philippine foreign service establishment, post, or the equivalent office having jurisdiction over the foreign bidder's affairs in the Philippines. For Contracting Parties to the Apostille Convention, only the translated documents shall be authenticated through an apostille pursuant to GPPB Resolution No. 13-2019 dated 23 May 2019. The English translation shall govern, for purposes of interpretation of the bid.
- 10.3. A valid special PCAB License in case of Joint Ventures, and registration for the type and cost of the contract for this Project. Any additional type of Contractor license or permit shall be indicated in the **BDS**.
- 10.4. A List of Contractor's key personnel (e.g., Project Manager, Project Engineers, Materials Engineers, and Foremen) assigned to the contract to be bid, with their complete qualification and experience data shall be provided. These key personnel must meet the required minimum years of experience set in the **BDS**.
- 10.5. A List of Contractor's major equipment units, which are owned, leased, and/or under purchase agreements, supported by proof of ownership, certification of availability of equipment from the equipment lessor/vendor for the duration of the project, as the case may be, must meet the minimum requirements for the contract set in the **BDS**.

## **11. Documents Comprising the Bid: Financial Component**

- 11.1. The second bid envelope shall contain the financial documents for the Bid as specified in **Section IX. Checklist of Technical and Financial Documents**.
- 11.2. Any bid exceeding the ABC indicated in paragraph 1 of the **IB** shall not be accepted.
- 11.3. For Foreign-funded procurement, a ceiling may be applied to bid prices provided the conditions are met under Section 31.2 of the 2016 revised IRR of RA No. 9184.

## **12. Alternative Bids**

Bidders shall submit offers that comply with the requirements of the Bidding Documents, including the basic technical design as indicated in the drawings and specifications. Unless there is a value engineering clause in the **BDS**, alternative Bids shall not be accepted.

## **13. Bid Prices**

All bid prices for the given scope of work in the Project as awarded shall be considered as fixed prices, and therefore not subject to price escalation during contract implementation, except under extraordinary circumstances as determined by the NEDA

and approved by the GPPB pursuant to the revised Guidelines for Contract Price Escalation guidelines.

#### **14. Bid and Payment Currencies**

14.1. Bid prices may be quoted in the local currency or tradeable currency accepted by the BSP at the discretion of the Bidder. However, for purposes of bid evaluation, Bids denominated in foreign currencies shall be converted to Philippine currency based on the exchange rate as published in the BSP reference rate bulletin on the day of the bid opening.

14.2. Payment of the contract price shall be made in:

**Philippine Pesos**

#### **15. Bid Security**

15.1. The Bidder shall submit a Bid Securing Declaration or any form of Bid Security in the amount indicated in the **BDS**, which shall be not less than the percentage of the ABC in accordance with the schedule in the **BDS**.

15.2. The Bid and bid security shall **be valid for 120 days from the bid submission**. Any bid not accompanied by an acceptable bid security shall be rejected by the Procuring Entity as non-responsive.

#### **16. Sealing and Marking of Bids**

Each Bidder shall submit one copy of the first and second components of its Bid.

The Procuring Entity may request additional hard copies and/or electronic copies of the Bid. However, failure of the Bidders to comply with the said request shall not be a ground for disqualification.

If the Procuring Entity allows the submission of bids through online submission to the given website or any other electronic means, the Bidder shall submit an electronic copy of its Bid, which must be digitally signed. An electronic copy that cannot be opened or is corrupted shall be considered non-responsive and, thus, automatically disqualified.

#### **17. Deadline for Submission of Bids**

The Bidders shall submit on the specified date and time and either at its physical address or through online submission as indicated in paragraph 7 of the **IB**.

#### **18. Opening and Preliminary Examination of Bids**

18.1. The BAC shall open the Bids in public at the time, on the date, and at the place specified in paragraph 9 of the **IB**. The Bidders' representatives who are present shall sign a register evidencing their attendance. In case videoconferencing, webcasting or other similar technologies will be used, attendance of participants shall likewise be recorded by the BAC Secretariat.



In case the Bids cannot be opened as scheduled due to justifiable reasons, the rescheduling requirements under Section 29 of the 2016 revised IRR of RA No. 9184 shall prevail.

- 18.2. The preliminary examination of Bids shall be governed by Section 30 of the 2016 revised IRR of RA No. 9184.

## **19. Detailed Evaluation and Comparison of Bids**

- 19.1. The Procuring Entity's BAC shall immediately conduct a detailed evaluation of all Bids rated "*passed*" using non-discretionary pass/fail criteria. The BAC shall consider the conditions in the evaluation of Bids under Section 32.2 of 2016 revised IRR of RA No. 9184.
- 19.2. If the Project allows partial bids, all Bids and combinations of Bids as indicated in the **BDS** shall be received by the same deadline and opened and evaluated simultaneously so as to determine the Bid or combination of Bids offering the lowest calculated cost to the Procuring Entity. Bid Security as required by **ITB** Clause 15 shall be submitted for each contract (lot) separately.
- 19.3. In all cases, the NFCC computation pursuant to Section 23.4.2.6 of the 2016 revised IRR of RA No. 9184 must be sufficient for the total of the ABCs for all the lots participated in by the prospective Bidder.

## **20. Post Qualification**

Within a non-extendible period of five (5) calendar days from receipt by the Bidder of the notice from the BAC that it submitted the Lowest Calculated Bid, the Bidder shall submit its latest income and business tax returns filed and paid through the BIR Electronic Filing and Payment System (eFPS), and other appropriate licenses and permits required by law and stated in the **BDS**.

## **21. Signing of the Contract**

The documents required in Section 37.2 of the 2016 revised IRR of RA No. 9184 shall form part of the Contract. Additional Contract documents are indicated in the **BDS**.

## ***Section III. Bid Data Sheet***

# Bid Data Sheet

ITB Clause																									
5.2	<p>For this purpose, contracts similar to the Project refer to contracts which have the same major categories of work, which shall be:</p> <p>Single Project for the Supply of Materials and Labor for the Construction of Medium Voltage Overhead and Underground Power System.</p>																								
7.1	Subcontracting is not allowed																								
10.3	<p>A valid and current PCAB License with principal classification in specialty SP-EE (electrical works) with the size range of Medium B, License Category A</p> <p>In the case of a Joint Venture, a Special PCAB License</p>																								
10.4	<p>The key personnel must meet the required minimum years of experience set below:</p> <table border="1" style="width: 100%; border-collapse: collapse; margin-top: 10px;"> <thead> <tr> <th style="width: 60%; text-align: center;"><u>Key Personnel</u></th> <th style="width: 40%; text-align: center;"><u>General Experience</u></th> </tr> </thead> <tbody> <tr> <td>Project Manager Electrical (PEE)</td> <td style="text-align: center;">10 yrs</td> </tr> <tr> <td>Project Manager Civil (PCE)</td> <td style="text-align: center;">10 yrs</td> </tr> <tr> <td>QA/QC Inspector Electrical</td> <td style="text-align: center;">5 yrs</td> </tr> <tr> <td>QA/QC Inspector Civil</td> <td style="text-align: center;">5 yrs</td> </tr> <tr> <td>Civil Supervisor</td> <td style="text-align: center;">5 yrs</td> </tr> <tr> <td>Electrical Supervisor Engineer</td> <td style="text-align: center;">5 yrs</td> </tr> <tr> <td>Safety Officer (SO3)</td> <td style="text-align: center;">1 yr</td> </tr> </tbody> </table>	<u>Key Personnel</u>	<u>General Experience</u>	Project Manager Electrical (PEE)	10 yrs	Project Manager Civil (PCE)	10 yrs	QA/QC Inspector Electrical	5 yrs	QA/QC Inspector Civil	5 yrs	Civil Supervisor	5 yrs	Electrical Supervisor Engineer	5 yrs	Safety Officer (SO3)	1 yr								
<u>Key Personnel</u>	<u>General Experience</u>																								
Project Manager Electrical (PEE)	10 yrs																								
Project Manager Civil (PCE)	10 yrs																								
QA/QC Inspector Electrical	5 yrs																								
QA/QC Inspector Civil	5 yrs																								
Civil Supervisor	5 yrs																								
Electrical Supervisor Engineer	5 yrs																								
Safety Officer (SO3)	1 yr																								
10.5	<p>The minimum major equipment requirements are the following:</p> <table border="1" style="width: 100%; border-collapse: collapse; margin-top: 10px;"> <thead> <tr> <th style="width: 70%; text-align: center;"><u>Equipment</u></th> <th style="width: 30%; text-align: center;"><u>Number of Units</u></th> </tr> </thead> <tbody> <tr> <td>Backhoe Long Arm 0.5 cu.m</td> <td style="text-align: center;">2.00</td> </tr> <tr> <td>Hydraulic Concrete Rock Breaker</td> <td style="text-align: center;">1.00</td> </tr> <tr> <td>Telescoping Boom truck 5 Tonner</td> <td style="text-align: center;">1.00</td> </tr> <tr> <td>Heavy Duty Air Compressor w/ Jackhammer/ Jacklegs</td> <td style="text-align: center;">2.00</td> </tr> <tr> <td>Road Roller Vibro Compactor</td> <td style="text-align: center;">1.00</td> </tr> <tr> <td>Pick-up Truck 4x2 or 4x4</td> <td style="text-align: center;">2.00</td> </tr> <tr> <td>Generator Set at least 30Kva</td> <td style="text-align: center;">2.00</td> </tr> <tr> <td>Winch Pulling Machine</td> <td style="text-align: center;">2.00</td> </tr> <tr> <td>Concrete Vibrator</td> <td style="text-align: center;">2.00</td> </tr> <tr> <td> </td> <td> </td> </tr> <tr> <td>One Bagger Mixer</td> <td style="text-align: center;">2.00</td> </tr> </tbody> </table>	<u>Equipment</u>	<u>Number of Units</u>	Backhoe Long Arm 0.5 cu.m	2.00	Hydraulic Concrete Rock Breaker	1.00	Telescoping Boom truck 5 Tonner	1.00	Heavy Duty Air Compressor w/ Jackhammer/ Jacklegs	2.00	Road Roller Vibro Compactor	1.00	Pick-up Truck 4x2 or 4x4	2.00	Generator Set at least 30Kva	2.00	Winch Pulling Machine	2.00	Concrete Vibrator	2.00			One Bagger Mixer	2.00
<u>Equipment</u>	<u>Number of Units</u>																								
Backhoe Long Arm 0.5 cu.m	2.00																								
Hydraulic Concrete Rock Breaker	1.00																								
Telescoping Boom truck 5 Tonner	1.00																								
Heavy Duty Air Compressor w/ Jackhammer/ Jacklegs	2.00																								
Road Roller Vibro Compactor	1.00																								
Pick-up Truck 4x2 or 4x4	2.00																								
Generator Set at least 30Kva	2.00																								
Winch Pulling Machine	2.00																								
Concrete Vibrator	2.00																								
One Bagger Mixer	2.00																								

	Machine 300Amp	2.00
	OxyAcetylene gas welding and cutting outfit	2.00
	Electric Rebar Bending Machine	1.00
	High Pressure Power Washer	2.00
	Water pump ( Electrical and Mechanical )	4.00
	Tamping Rammer	1.00
12	Alternative bids shall not be accepted	
15.1	<p>The bid security shall be in the form of a Bid Securing Declaration or any of the following forms and amounts:</p> <p>a. The amount of not less than Php2,038,834.94 (Lot 1) and Php3,592,233.00 (Lot 2), if bid security is in cash, cashier's/manager's check, bank draft/guarantee or irrevocable letter of credit;</p> <p>b. The amount of not less than Php5,097,087.35 (Lot 1) and Php8,980,582.50 (Lot 2), if bid security is in Surety Bond.</p>	
16	<p>Each bidder shall submit One (1) original/certified true copies and Two (2) photocopies of the technical and financial components of its bid:</p> <p>One (1) original/certified true copy labeled as "Original" and two (2) photocopies thereof labeled as "Copy 1" and "Copy 2" respectively.</p> <p>The bidders shall enclose the technical components (eligibility and technical documents) in one sealed envelope and the financial component in another sealed envelope</p>	
19.2	Partial bids are not allowed	
20	Income and business tax returns filed and paid through the BIR Electronic Filing and Payment System (eFPS) for the last six months.	
21	Additional contract documents relevant to the Project that may be required by existing laws and/or the Procuring Entity, such as construction schedule and S-curve, manpower schedule, construction methods, equipment utilization schedule, construction safety and health program approved by the DOLE, and other acceptable tools of project scheduling.	

## ***Section IV. General Conditions of Contract***

## 1. **Scope of Contract**

This Contract shall include all such items, although not specifically mentioned, that can be reasonably inferred as being required for its completion as if such items were expressly mentioned herein. All the provisions of RA No. 9184 and its 2016 revised IRR, including the Generic Procurement Manual, and associated issuances, constitute the primary source for the terms and conditions of the Contract, and thus, applicable in contract implementation. Herein clauses shall serve as the secondary source for the terms and conditions of the Contract.

This is without prejudice to Sections 74.1 and 74.2 of the 2016 revised IRR of RA No. 9184 allowing the GPPB to amend the IRR, which shall be applied to all procurement activities, the advertisement, posting, or invitation of which were issued after the effectivity of the said amendment.

## 2. **Sectional Completion of Works**

If sectional completion is specified in the **Special Conditions of Contract (SCC)**, references in the Conditions of Contract to the Works, the Completion Date, and the Intended Completion Date shall apply to any Section of the Works (other than references to the Completion Date and Intended Completion Date for the whole of the Works).

## 3. **Possession of Site**

3.1 The Procuring Entity shall give possession of all or parts of the Site to the Contractor based on the schedule of delivery indicated in the **SCC**, which corresponds to the execution of the Works. If the Contractor suffers delay or incurs cost from failure on the part of the Procuring Entity to give possession in accordance with the terms of this clause, the Procuring Entity's Representative shall give the Contractor a Contract Time Extension and certify such sum as fair to cover the cost incurred, which sum shall be paid by Procuring Entity.

3.2 If possession of a portion is not given by the above date, the Procuring Entity will be deemed to have delayed the start of the relevant activities. The resulting adjustments in contract time to address such delay may be addressed through contract extension provided under Annex "E" of the 2016 revised IRR of RA No. 9184.

## 4. **The Contractor's Obligations**

The Contractor shall employ the key personnel named in the Schedule of Key Personnel indicating their designation, in accordance with **ITB** Clause 10.3 and specified in the **BDS**, to carry out the supervision of the Works.

The Procuring Entity will approve any proposed replacement of key personnel only if their relevant qualifications and abilities are equal to or better than those of the personnel listed in the Schedule.

## **5. Performance Security**

- 5.1. Within ten (10) calendar days from receipt of the Notice of Award from the Procuring Entity but in no case later than the signing of the contract by both parties, the successful Bidder shall furnish the performance security in any of the forms prescribed in Section 39 of the 2016 revised IRR.
- 5.2. The Contractor, by entering into the Contract with the Procuring Entity, acknowledges the right of the Procuring Entity to institute action pursuant to RA No. 3688 against any subcontractor be they an individual, firm, partnership, corporation, or association supplying the Contractor with labor, materials and/or equipment for the performance of this Contract.

## **6. Site Investigation Reports**

The Contractor, in preparing the Bid, shall rely on any Site Investigation Reports referred to in the SCC supplemented by any information obtained by the Contractor.

## **7. Warranty**

- 7.1. In case the Contractor fails to undertake the repair works under Section 62.2.2 of the 2016 revised IRR, the Procuring Entity shall forfeit its performance security, subject its property(ies) to attachment or garnishment proceedings, and perpetually disqualify it from participating in any public bidding. All payables of the GOP in his favor shall be offset to recover the costs.
- 7.2. The warranty against Structural Defects/Failures, except that occasioned-on force majeure, shall cover the period from the date of issuance of the Certificate of Final Acceptance by the Procuring Entity. Specific duration of the warranty is found in the SCC.

## **8. Liability of the Contractor**

Subject to additional provisions, if any, set forth in the SCC, the Contractor's liability under this Contract shall be as provided by the laws of the Republic of the Philippines.

If the Contractor is a joint venture, all partners to the joint venture shall be jointly and severally liable to the Procuring Entity.

## **9. Termination for Other Causes**

Contract termination shall be initiated in case it is determined *prima facie* by the Procuring Entity that the Contractor has engaged, before, or during the implementation of the contract, in unlawful deeds and behaviors relative to contract acquisition and implementation, such as, but not limited to corrupt, fraudulent, collusive, coercive, and obstructive practices as stated in ITB Clause 4.

## **10. Dayworks**

Subject to the guidelines on Variation Order in Annex “E” of the 2016 revised IRR of RA No. 9184, and if applicable as indicated in the SCC, the Dayworks rates in the Contractor’s Bid shall be used for small additional amounts of work only when the Procuring Entity’s Representative has given written instructions in advance for additional work to be paid for in that way.

## **11. Program of Work**

11.1. The Contractor shall submit to the Procuring Entity’s Representative for approval the said Program of Work showing the general methods, arrangements, order, and timing for all the activities in the Works. The submissions of the Program of Work are indicated in the SCC.

11.2. The Contractor shall submit to the Procuring Entity’s Representative for approval an updated Program of Work at intervals no longer than the period stated in the SCC. If the Contractor does not submit an updated Program of Work within this period, the Procuring Entity’s Representative may withhold the amount stated in the SCC from the next payment certificate and continue to withhold this amount until the next payment after the date on which the overdue Program of Work has been submitted.

## **12. Instructions, Inspections and Audits**

The Contractor shall permit the GOP or the Procuring Entity to inspect the Contractor’s accounts and records relating to the performance of the Contractor and to have them audited by auditors of the GOP or the Procuring Entity, as may be required.

## **13. Advance Payment**

The Procuring Entity shall, upon a written request of the Contractor which shall be submitted as a Contract document, make an advance payment to the Contractor in an amount not exceeding fifteen percent (15%) of the total contract price, to be made in lump sum, or at the most two installments according to a schedule specified in the SCC, subject to the requirements in Annex “E” of the 2016 revised IRR of RA No. 9184.

## **14. Progress Payments**

The Contractor may submit a request for payment for Work accomplished. Such requests for payment shall be verified and certified by the Procuring Entity’s Representative/Project Engineer. Except as otherwise stipulated in the SCC, materials and equipment delivered on the site but not completely put in place shall not be included for payment.

## **15. Operating and Maintenance Manuals**

15.1. If required, the Contractor will provide “as built” Drawings and/or operating and maintenance manuals as specified in the SCC.



- 15.2. If the Contractor does not provide the Drawings and/or manuals by the dates stated above, or they do not receive the Procuring Entity's Representative's approval, the Procuring Entity's Representative may withhold the amount stated in the SCC from payments due to the Contractor.

## ***Section V. Special Conditions of Contract***

# Special Conditions of Contract

GCC Clause	
2	Not applicable
3.1	Upon issuance of Notice to Proceed
6	The site investigation reports are: Site Inspection Certificate
7.2	Fifteen (15) years.
10	Dayworks are applicable at the rate shown in the Contractor's original Bid.
11.1	The Contractor shall submit the Program of Work to the Procuring Entity's Representative within ten (10) days of delivery of the Notice of Award.
11.2	The updated program must be submitted within 7 days upon request of the Procuring Entity. The amount to be withheld for late submission of an updated Program of Work is 5% of the next progress payment
13	The amount of the advance payment is 15% of the total contract price. The advance payment shall be made only upon the submission to and acceptance by the procuring entity of an irrevocable standby letter of credit of equivalent value from a commercial bank, a bank guarantee or a surety bond callable upon demand, issued by a surety or insurance company duly licensed by the Insurance Commission and confirmed by the procuring entity
14	Materials and equipment delivered on the site but not completely put in place may <b>be</b> included in payment.
15.1	The date by which operating and maintenance manuals are required is 15 days upon completion of project. The date by which "as built" drawings are required is 15 days upon completion of project.
15.2	The amount to be withheld for failing to produce "as built" drawings and/or operating and maintenance manuals by the date required is 10% retention.

## *Section VI. Specifications*

# *Technical Specifications*

## **Cable Specifications:**

1. Voltage rating: Medium Voltage 8.7/ 15 (17.5) kV Aluminum conductor with copper tape shield.
2. Conductor: Single core compact round-stranded Aluminum of 85 mm<sup>2</sup> stranded wire
3. Conductor shield: Semi-conducting cross-link polyethylene (XLPE)
4. Insulation: XLPE cross-link polyethylene
5. Insulation shield: Semi-conducting cross-linked polyethylene
6. Metallic shield: Uncoated copper tape wrapped around the length of the cable
7. Oversheath: Black PE (ST 7) PVC sheath outer cover or equivalent
8. Ampacity: 250 amperes in trefoil formation, buried in duct bank

## **Construction Installation condition:**

1. With maximum conductor temperature: 90 ° C (Normal Operation)
2. AC Test voltage: 30.5 kV for 5 minutes
3. Reference standard: IEC 60502-2
4. Ambient temperature: 40° C
5. Ground temperature: 30° C
6. Depth of laying (min.): 1200 mm below ground level
7. Type of underground installation: XLPE cable inside uPVC conduit pipes of duct bank arranged in quad formation.
8. Thermal resistivity of soil: 1.2 K-m/W
9. Axial spacing between phase cable: Arrange in triangle formation 300 mm Spacing (duct bank in quad formation, 300mm x 300mm) with a fourth conduit for Neutral wire and ground.
10. Cable shields: Bonded at a single location

The 15kV XLPE cables are installed inside Unplasticized PolyVinyl Chloride (uPVC) conduit pipes of 110mm inside diameter arranged in quad formation and embedded in 1.20-meter depth. The details of the construction of the underground distribution network for Phase 3 and Phase 4 are explained under construction design consideration.

## **Underground Distribution System Design**

The overall design for APECO's 13.2kV underground distribution feeder lines is connected with underground distribution switchgear which is designed to carry the demand of 250 Amperes. The single core 15 kV 1/c x 85mm<sup>2</sup> XLPE cable is rated 250 Amperes installed inside the duct bank below ground with consideration of the voltage drop and short circuit capacity of the underground cable.

The feeder circuit loop connection is connected, and the circuit is disconnected from one of its UGD switchgear with its disconnecting switch (DS) in "N.O. (Normally Open condition) preventing parallel operation of the power supply. The 13.2kV underground distribution system XLPE cables are terminated to each 15kV UGD switchgears with its disconnect switches at both ends and with vacuum circuit breakers (VCB) on the switchgear. This is part of the

switching operation for maintenance and during fault conditions (switching isolating and re-energize back the healthy portion of the feeder circuit).

### Design of Underground Distribution Switchgear

This underground distribution switchgear is a pad mounted type switchgear designed as either mineral oil insulated or SF6 gas insulation with a VCB built on vacuum bottles. The VCB absorbs the arcing during the closing and opening of the breaker. These UGD switchgears are type tested switchgears following IEC standards IEC 62271-100, 102, 105, 200 and 202.

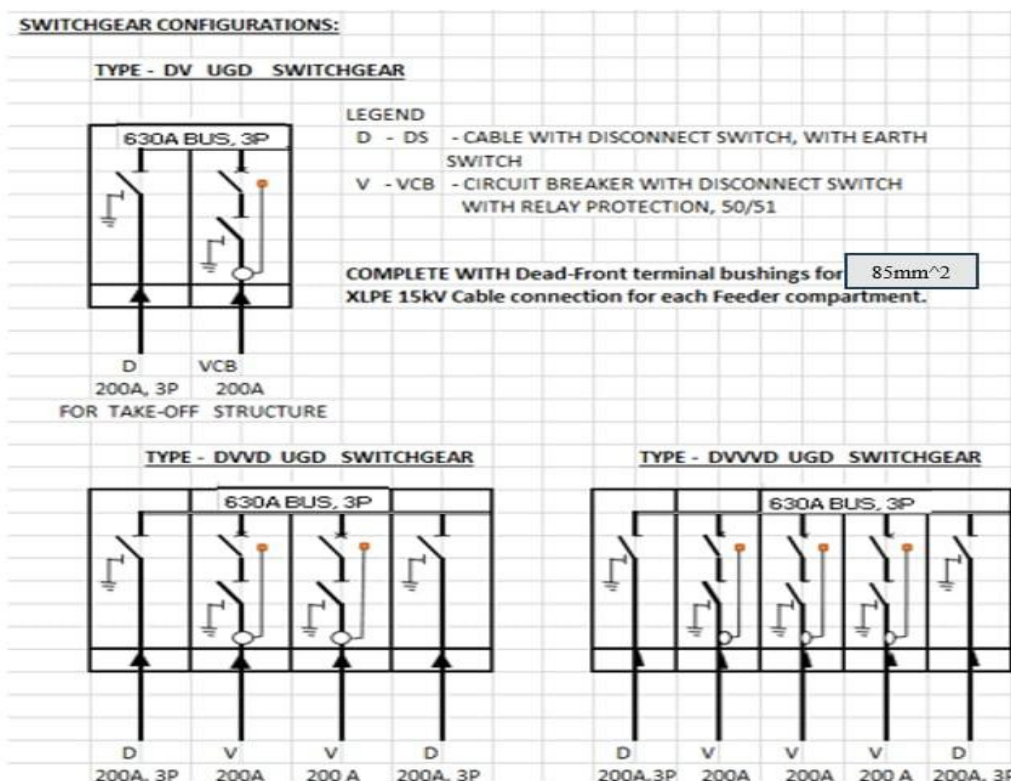
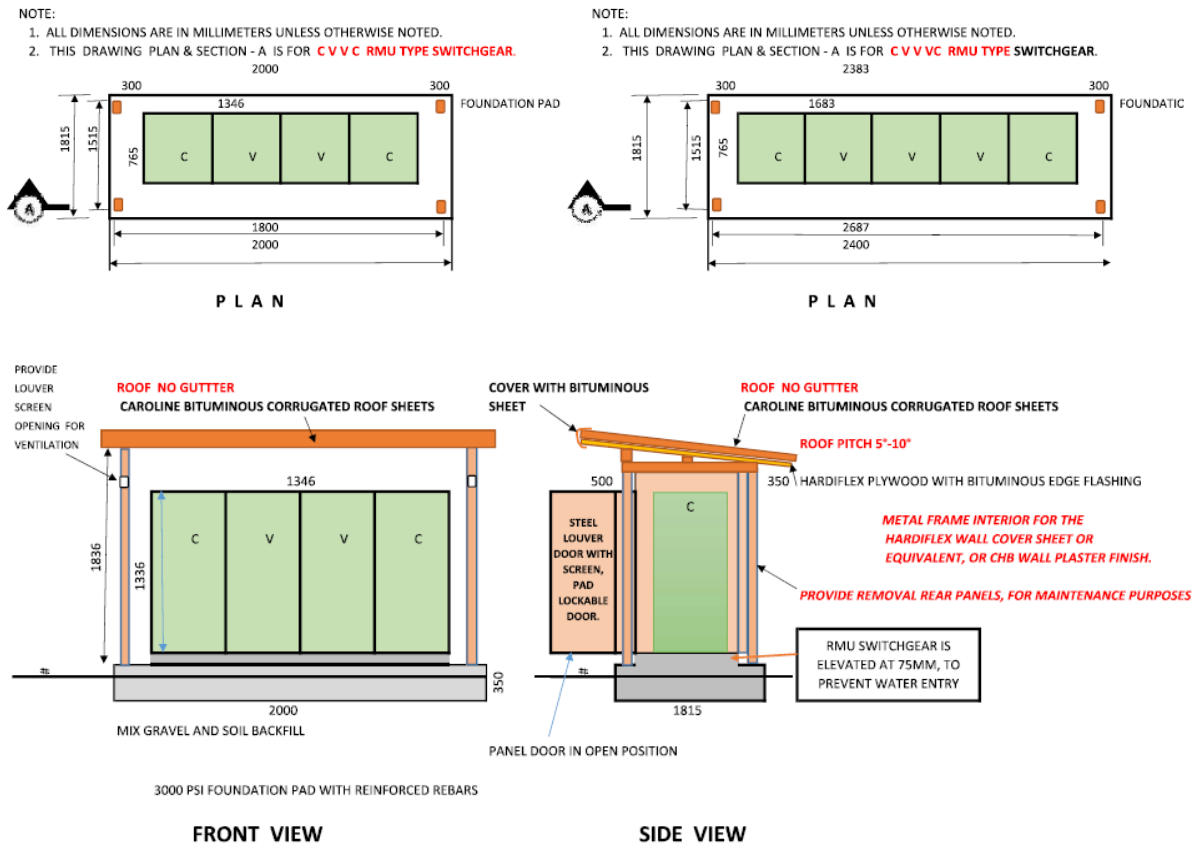


Figure 4. Switchgear Configurations

### Design of the Outdoor Type Housing for the Switchgears

The UGD switchgears are designed to be outdoor type. The switchgears are installed on a reinforced concrete pad and the housing is designed with a steel column frame square tube and at sides with CHB concrete wall finished. The rear housing cover is made of steel sheets painted with epoxy primer paint and a final coat of paint finish. The rear panels are removed with screw fasteners and at front door panels are provided with pad-lockable panel doors. Figure 5 below shows the Plan and Sections views of the Padmount UGD switchgear housing.

**FOUNDATION PAD DETAILS**



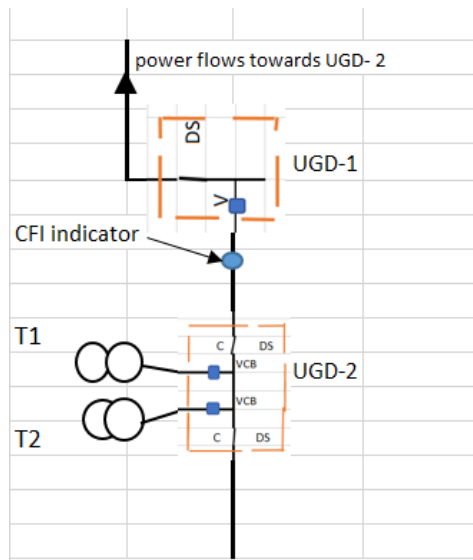
**Figure 5. Plan and Sections views of the Padmount UGD Switchgear Housing**

**Underground Distribution Network Design**

The 15kV UGD switchgear is interconnected to other UGD switchgear using the 15kV XLPE cables to complete a loop circuit, however, one end of the DS of the UGD switchgear will be in “N.O. Normally Open” condition. This arrangement of loop interconnection will provide flexibility in the power supply especially whenever a fault occurs on a particular circuit, or from pad mount transformer or a feeder cable fault. Each pad mount transformer is protected by a CB vacuum circuit breaker with each respective 50/51 overcurrent and overload protection device. The VCB vacuum circuit breakers will operate to open the circuit isolating the fault along each pad mount transformer and its feeder circuit as applied in the circuit.

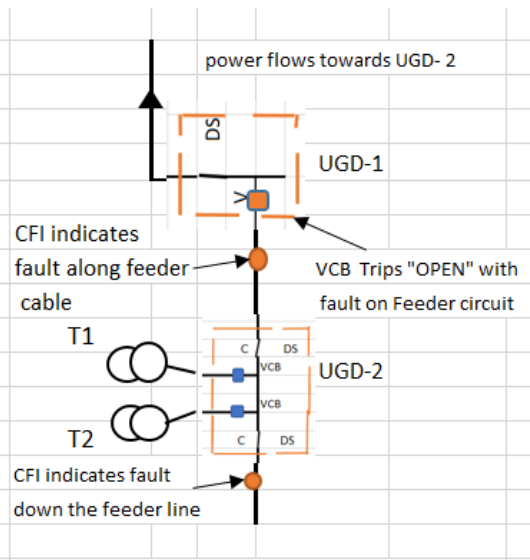
The protection devices installed at each vacuum circuit breaker detects faults on the line and TRIP “OPEN” the circuit breaker to isolate the fault, preventing damage to the transformers and or main feeder XLPE cables for each circuit. The VCB breaker can be reset to close (energize “ON”) the VCB circuit with the Transformer or the feeder circuit. See below diagram 1 (Fault at T1 transformer) and diagram 2 (Fault along Feeder circuit).

## OHL CONNECTION



**Diagram 1**, shows VCB of UGD-1 in normal condition on the Feeder circuit.

## OHL CONNECTION



**Diagram 2**, shows VCB of UGD-1 Trips "OPEN" to isolate the fault on the Feeder circuit.

Once the fault is found in a circuit, the portion of the circuit can be isolated as in diagram 1, the VCB Trips "OPEN" to de-energize the T1 transformer.

While on Diagram 2, the main UGD-1 switchgear VCB Trips "OPEN" the feeder circuit whenever fault is detected along the feeder circuit. The fault as per diagram is down the feeder line. The CFI cable fault indicator detects the fault down its feeder circuit. To remedy the fault on the feeder circuit, the lineman inspects and surveys each UGD switchgear to look for the CFI cable fault indicator that has turned (Red) indication the fault is down this feeder circuit from the UGD switchgear unit. Thus the fault is found and the isolating process of the feeder circuit begins as follows.

At UGD-2, open the DS, C2 to isolate the UGD-2 which has healthy feeder circuits.

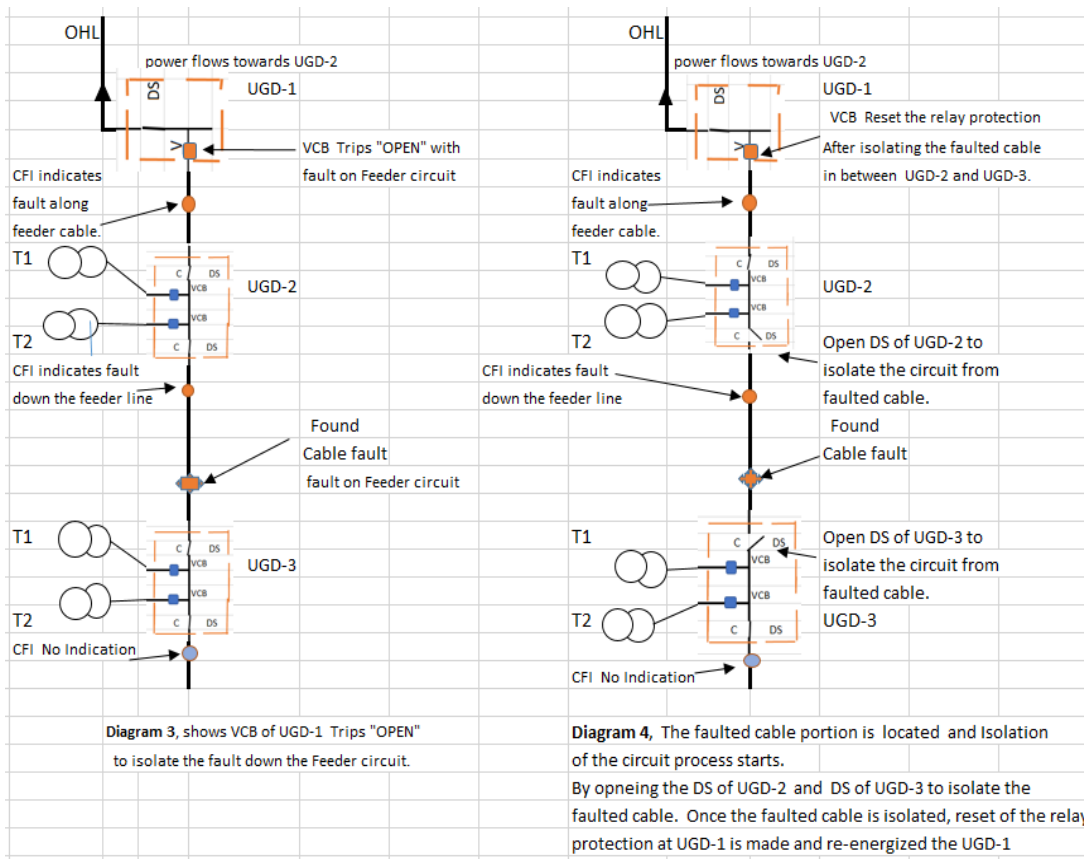
At UGD-3, open the DS, C1 to isolate the UGD-3 upper feeder circuit with cable fault.

At UGD-3, close the DS, C2 so we can re-energized back UGD-3 to energize back the two transformers T1 and T2.

At UGD-1, we reset the relay protection unit in order that the VCB can be closed and energized back the feeder circuit. At this point only the healthy feeder circuits of UGD-1 and UGD-2 will be energized back and the transformers connected to it will be energized.

At UGD-4 the switchgear which has its DS, C1 in open position, we can close this so that power can flow through from the other Feeder circuit 1. Thus, energizing back the UGD-3 and energizing the T1 and T2 transformers.





With the damaged (faulted) cable found, the cable replacement can be undertaken by scheduled outage when the actual cable removal and insertion/installation of the damaged XLPE cable.

This is the main advantage of the Loop feed underground distribution network wherein faults can be isolated and the other circuit which has healthy condition can get the power source from the other (feeder other loop) circuit. All the UGD switchgear cable connections are provided with fault indicators. They are installed clamped on the cable ends. Whenever fault occurs, the fault indicator will show a Red flag (meaning fault occurred on this circuit).

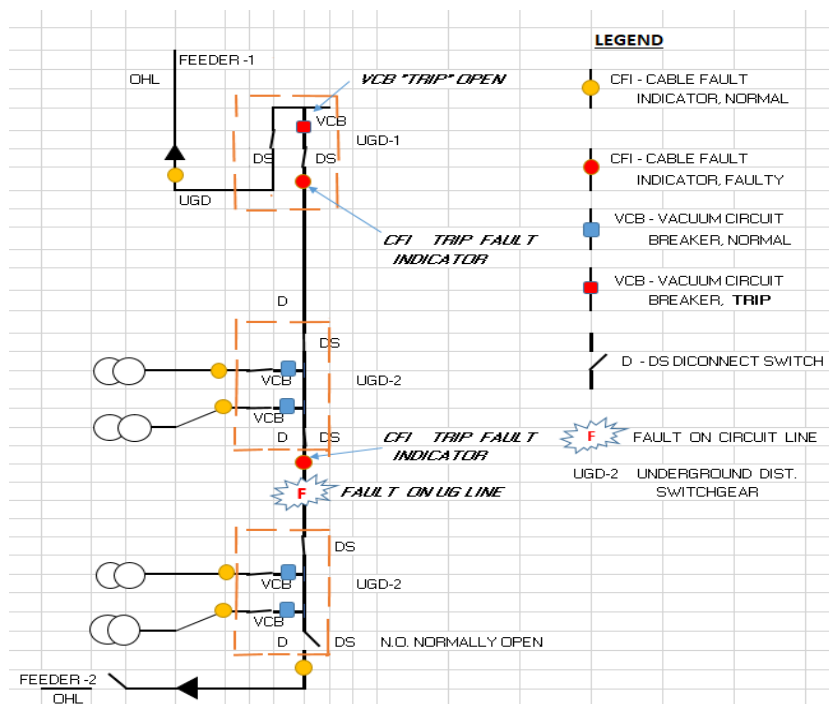
The cable loop connections are interconnected to two power sources of the supply of 13.2kV distribution network, however, for this project only one feeder would be connected to supply. Perhaps, the other feeder would be connected in the future as soon as APECO's locators (load) increases.

One of the UGD switchgear disconnect switches should be in (N.O.) normally "OPEN" position. This will allow to provide a separate power source for the two different feeders connecting Phase 4 and Phase 1 & Phase 2 and Phase 3 of the economic zone customers, avoiding parallel operation on the power supply. The proposed 15kV underground distribution network for APECO will be in loop feed type and all cables are bottom entry at each switchgear. The UGD switchgears are pad mounted type and are all mounted in concrete pad. The following are the accessories of the pad mount underground distribution switchgear for SF6 gas insulated:

1. Front cover compartment
2. SF6 gas gage
3. Pressure relief device
4. Dead-front terminal bushing (3 sets) per cubicle.
5. Terminal bushing stand, per each cubicle.
6. Disconnect switch handle (manual operation), the tool
7. Name plate rating
8. Relay protection unit

### Cable Fault Indicator (CFI)

For APECO's proposed underground distribution system expansion, consideration is applied to utilize this CFI cable fault indicators in order to identify the faulted circuit (cable or equipment) for all the underground cable feeders. The CFI type to be used for this project is the Test Point Rest (TPR) type.



**Diagram 5**

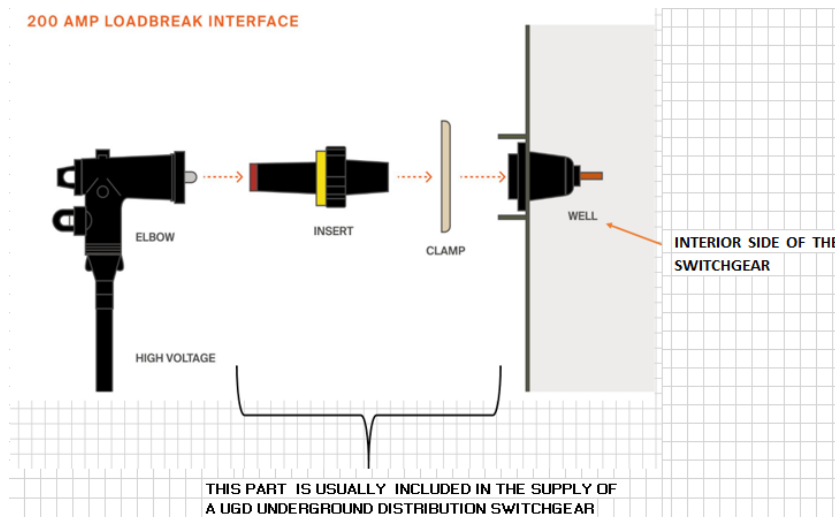
The CFI type to be used for this project is the Test Point Reset (TPR) type. This is installed on the dead-front cable elbow connector at each UGD underground distribution switchgears for each of the DS and VCB circuit breaker terminals. The TPR cable fault indicator is installed on the test point of the dead-front elbow connectors. Diagram 5, above shows the typical sample of installation of the CFI cable fault indicators on a looped underground distribution system.

The CFI indicators reset automatically upon restoration of the system power or after a predetermined time period when the circuit trouble has been resolved. The automatic resetting fault indicators sense either voltage or current to determine that power has been restored to the

system. The CFI units will reset to the normal position to eliminate the need for line personnel to manually reset the units. This saves time, money and makes the fault indicators more reliable.

The UG switchgears are designed to connect the pad mount transformers with its circuit breaker protection. In this underground distribution system project, we will cover only the underground duct bank and the interconnection of the UGD switchgears.

Similar to a pad mount transformer, the UGD switchgears are equipped with this Dead Front Elbow connectors where the 15 kV XLPE cable is terminated. Figure 6 below shows the blow-up view of the 200 ampere rated Dead-Front Elbow connectors.



**Figure 6. PRIMARY MV, SWITCHGEAR TERMINAL BUSHING**

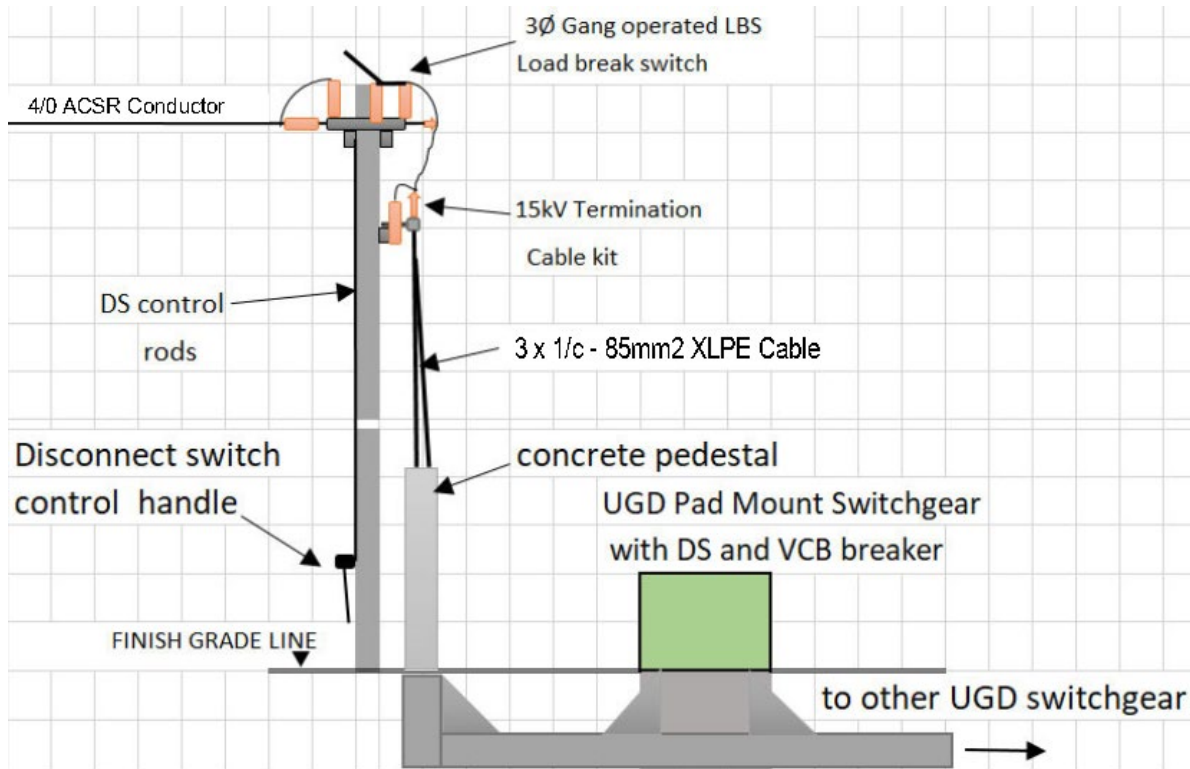
**Take-off Structure**

The proposed UGD underground distribution network for APECO 13.2 kV for Phase 3 and Phase 4, will be tapped for dedicated power supply of APECO.

All the tap connections of APECO for its Phase 3 and Phase 4 economic zone UGD underground distribution main feeder connections. Below are the three (3) UGD underground feeder circuits and its location.

APECO PROJECT PHASE NUMBER	FEEDER CIRCUIT NO.	LOCATION
Phase 1 & Phase 2	Feeder Circuit -1	Existing APECO power source from NAPOCOR
Phase 3	Feeder Circuit -2 (FUTURE)	APECO North East side of economic zone

Phase 4	Feeder Circuit– 2, Tap Connection to the Power Supply	APECO Southmost road of economic zone
---------	---	---------------------------------------

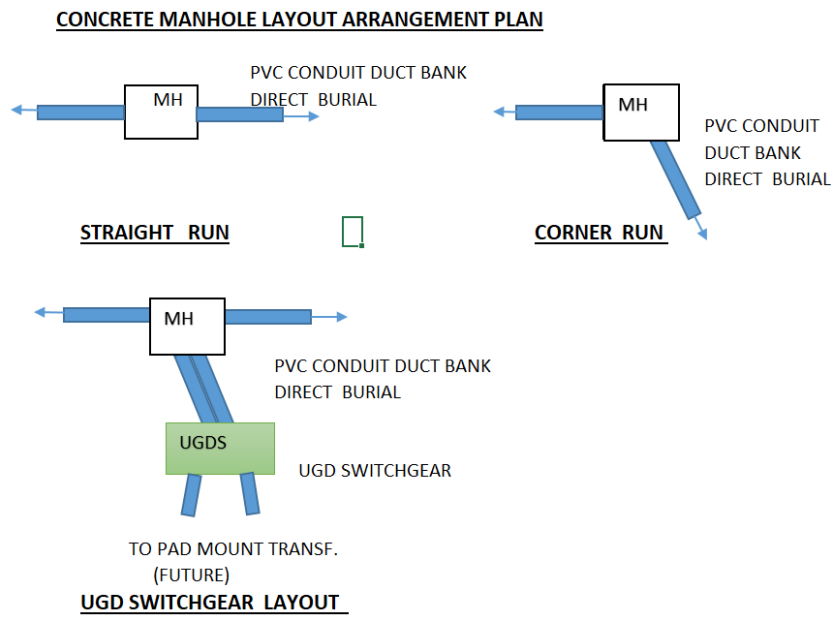


**Figure 7. Take-off Structure**

Figure 7 above shows the complete Take-off structure with its LBS 3-phase gang switch, Power fuse and surge arrester with the 15kV cable termination connection for the 15 kV UG underground cable and the pad mount UGD switchgear.

### **The Underground Distribution Network**

The 15kV underground distribution network is designed to provide a network of underground 15kV cables 3 x 85mm<sup>2</sup> XLPE rated 200 amperes and installed in 110mm dia. uPVC conduits are arranged in Quad layout below 1.5 meter depth at Phase 3 and Phase 4. There are concrete manholes provided and spread strategically along the UG network, where straight runs are limited up to 50 - 60 meters, and at corner runs and where the UGD switchgears are located. The pad mount transformers are not part of this project, however, a one meter length of the uPVC duct bank is provided at each UGD switchgears so that APECO may connect this to the prospective Locators at both Phase 3 and Phase 4.

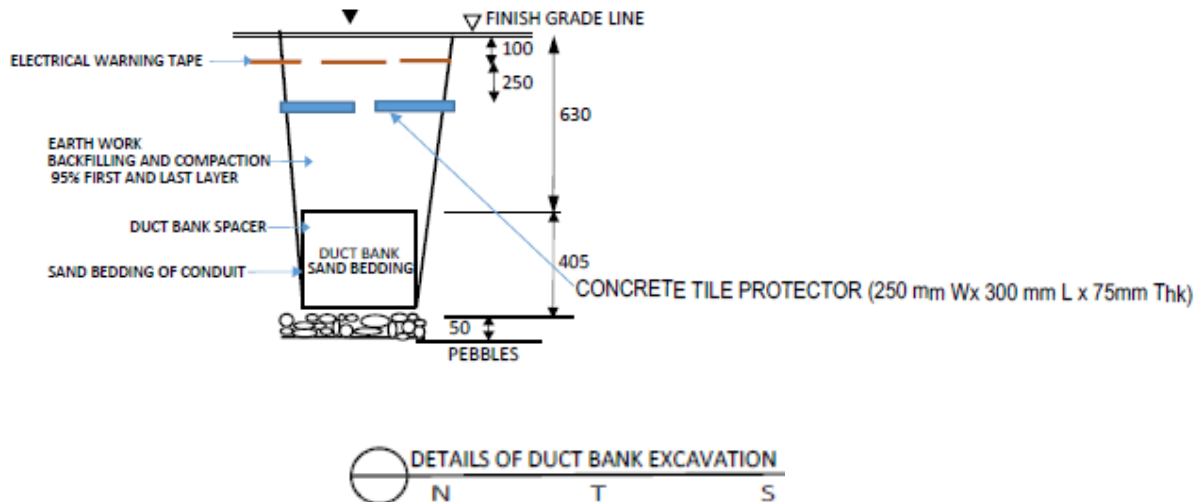


**Figure 8**

Figure 8 above shows the underground concrete manholes and duct bank arrangement at straight run, corner runs, and with UFD switchgear connections.

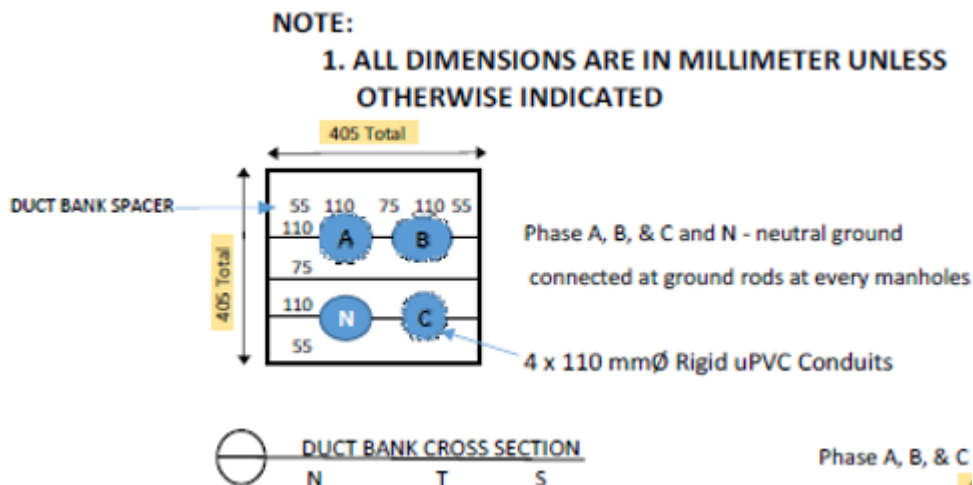
## Design of Underground Duct Bank

Below are the following design details of the underground duct bank which are mainly made of 4 – 110mm dia. uPVC and directly buried underground. At a depth of 1035 mm.



**Figure 9**

Figure 9 above shows the section view of the underground duct bank with the 4 – 110 mm dia. uPVC conduits arrange in Quad formation.



**Figure 10**

Figure 10 above shows the Quad arrangement of the underground duct bank with the 4 – 110 mm dia. uPVC conduits arrangement in Quad formation. Please note the 3 – 15kV XLPE Phasing, phase A, B and Phase C, while the N refers to the Neutral Line wire composed of 3/8” dia. Alumoweld-clad steel wire which is connected to ground at each manholes.

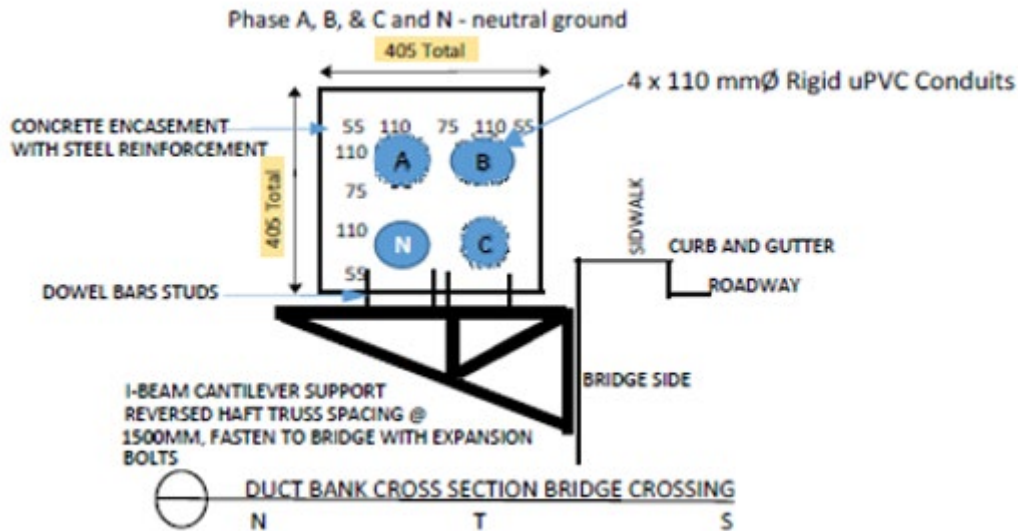


Figure 11

Figure 11, above shows the construction of the section view of the duct bank run along the length of the bridge. It is supported by steel angles at every 1000mm distance. The duct bank may be enclosed in concrete or the uPVC conduits are clamped in Quad formation.

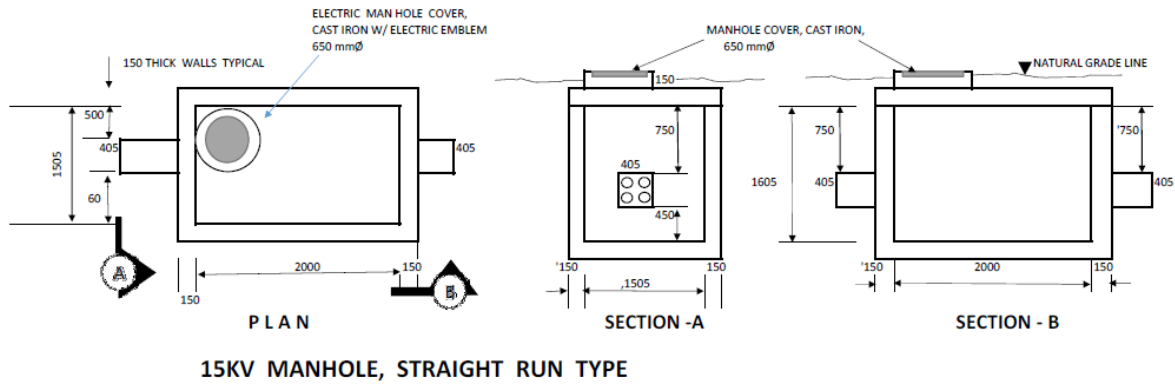
#### DESIGN CRITERIA OF THE UNDERGROUND DUCT BANK:

1. See Technical Specifications and Sand Bedding & Backfilling Requirements.
2. Class "A" Bedding shall be used in pipes for unstable soil or where directed by the engineer.
3. Class "B" Bedding shall be used under roadway and in unstable soil.
4. Class "C" Bedding shall be used in sidewalk areas.
5. Concrete Encasement shall be used under roadways or crossing roadways with cover less than 300 mm as well as duct bank crossing bridges shall be concrete encasement with steel reinforcement that has steel to concrete ratio not less than 0.85% which shall be support by I-Beam Cantilever reversed half truss that is anchor to the bridge expansion bolts or mechanical means that is sound structurally space at 1500 mm apart.
6. All concrete encasement duct runs and manholes, ground floor and suspend slab, and suspended concrete encasement duct runs shall have a compressive concrete strength not less than 30,000 psi including roadway restoration.
7. All concrete encasement duct runs and manhole, ground floor and suspend slab, and suspended concrete encasement duct runs shall be reinforced with steel grade 40 or 40,000 psi tensile strength mild steel.
8. For all non traffic type manhole steel to concrete ratio shall be not less than 0.75% or is to be increase if actual requirement on site is not sufficient shall be for all traffic type manhole steel to concrete ratio shall not be less than 1.5%.
9. All concrete spacer shall be 3,000 psi with one piece of steel reinforcement not less than 12 mm diameter grade 40 or 40,000 psi tensile strength.
10. Manhole cover shall be two types traffic and non-traffic type they will be heavy duty cast iron prepaint epoxy finished with embossed lettering indicating electrical high voltage utility with special locking mechanism for safety protection.
11. For unstable trench, excavation shall be modified as directed by the engineer to suit the correct actual field conditions.

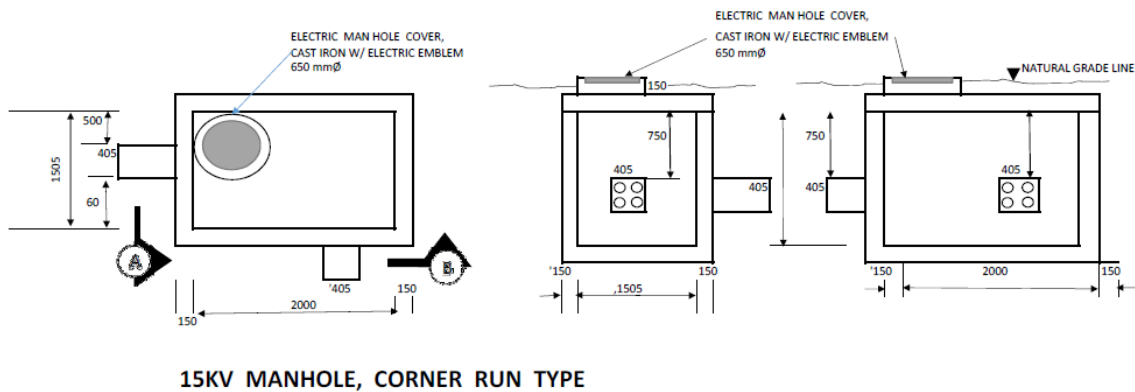
12. Backfilling and compaction per layer shall be every 200 mm thick with the first and last layer shall be 95% compaction, only where as the 2nd and succeeding layer shall be inspected visually by client representative and contractor QA/QC.

## MANHOLE DESIGN

The following are the concrete manhole design considerations such as the manhole covers, made of cast iron, internal accessories such as steel Step bars of 16 mm dia., Triangular pull bars which are all hot-dip galvanized finish. The Quad formation of the uPVC conduits are arranged for a straight flow of the power cables. The manholes are embedded underground at a depth of 1900 mm. A small floor opening of 300mm x 300mm serves as a natural drain, with mix gravel and sand.

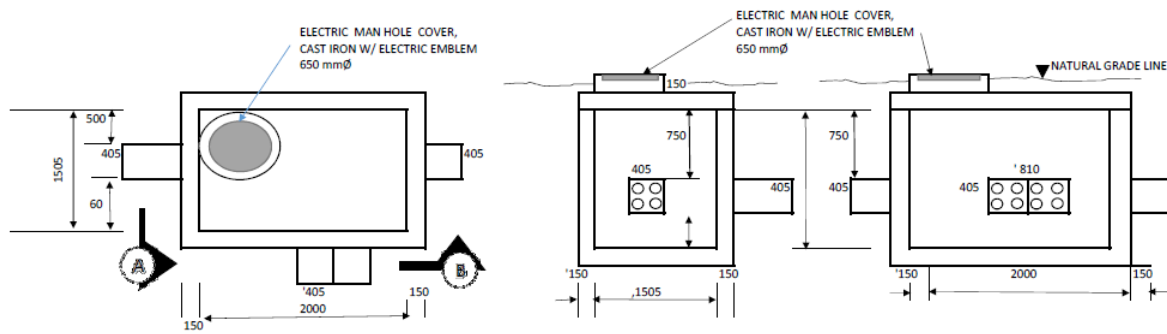


**Figure 12. STRAIGHT RUN TYPE**



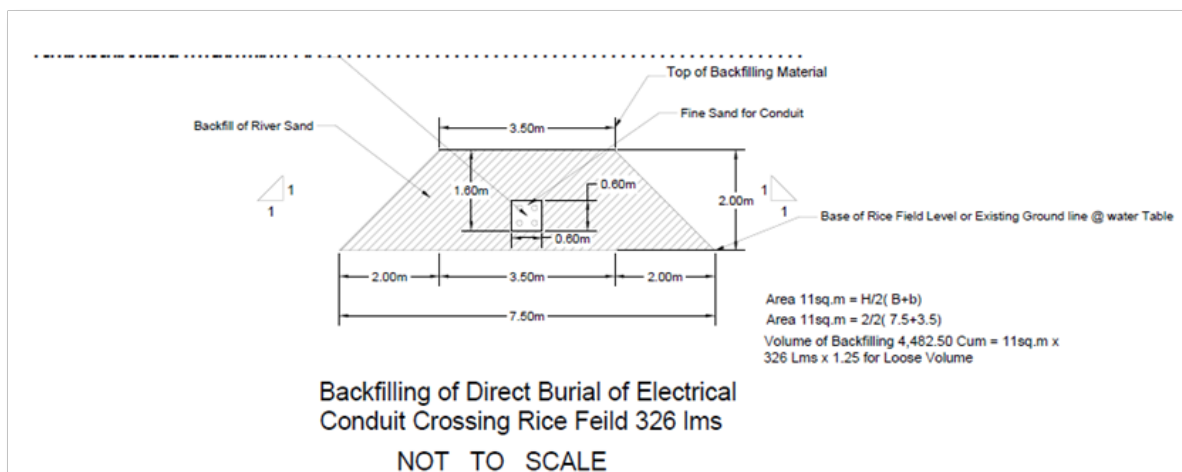
**Figure 13. CORNER RUN TYPE**





**Figure 14. TEE RUN TYPE (design specifically for connection to a Switchgear)**

## UNDERGROUND DESIGN FOR CROSSING RICE FIELD IN PHASE 4



**Figure 15. Underground Duct Bank Design for Crossing Rice Fields in Phase 4**

### General Design Considerations:

1. The cross-linked polyethylene (XLPE) insulation cable is rated 15 kV and is a single core round Aluminium stranded wire of 85mm<sup>2</sup> size. A copper shield tape is wound around the semi-conducting insulation for the ground connection of the cable. A final PVC jacket outer sheath serves as the outer protection cover of the cable. The ground connection of the 15kV XLPE cable is by single-end ground bonding for each of the XLPE cable connections from UGD pad-mounted switchgear and pad mount transformers.
2. The single core 15kV 85mm<sup>2</sup> XLPE Aluminium cable will be installed in a duct bank made of uPVC conduit pipes of 110 mm diameter and is arranged in Quad formation. The 3-phase single core conductor underground XLPE cables are to be installed underground on each respective rigid uPVC conduits, with the fourth conduit for the neutral ground wire. The duct bank shall be in quad formation and directly buried on the ground embedded with river sand all along the length of the duct bank from manhole to manhole and connects to UGD distribution switchgear and pad mount transformers.

3. Concrete manholes 2.0 meter length and 1.50 meter wide and 1.8 m depth inside dimensions are provided for corner run, straight runs with 40 – 60 meters span and a Tee- Run connection manhole solely for connection to each of the UGD switchgears. Each manholes are provided with steel step ladders, steel pull bars installed atop each of the four duct bank formation with a cast iron manhole cover of 500mm diameter.
4. The neutral ground wire passing through each of the manholes should be connected to a ground rod installed inside each of the manholes. The ground connection is connected both to ground rod 16 mm dia. X 3.0 meter hot-dip galvanized steel rod and the steel wire aluminum clad stranded wire 7 No.6 AWG, SW/AS aluminum clad steel wire by thermit weld connection.
5. At every manholes each single core XLPE cable should be provided with a one or 1-1/2 loop lengths inside the manhole for allowance length to be use when the 15kV elbow connectors are to be terminated to UGD switchgear, Pad mount transformers and take-off structure at concrete pedestal. This requirement is utilized if during installation an elbow connector fails, the damage XLPE cable ends should be cut and remove and extra length is to be pulled in from the manhole and a new elbow connector is installed and tested to complete the cable termination to each UGD switchgear, using the Dead-Front Elbow connectors. While at the take-off steel pole structure, APECO will construct a concrete pedestal with 4 x 110 mm dia. uPVC conduits with the 85mm<sup>2</sup> XLPE 15kV power cable will rise and connect to supply of 3 phase OHL distribution lines, using a Terminating kit as shown below.

#### **15kV XLPE CABLE TERMINATION WORKS**



ABOVE PHOTO SHOWS THE INDIVIDUAL XLPE CABLE TERMINATION ON A THREE PHASE CABLE TERMINATIONS FOR TAKE-OFF STRUCTURE APPLICATION. EITHER 3M COLD SHRINK TYPE OR HEAT SHRINK TYPE BY RAYCHEM CABLE TERMINATIONS RATED 15kV CLASS.

6. A concrete pedestal take-off structure for the vertical rise of four (4) uPVC conduit pipes of 3 meter length and 110mm dia. should be provided with end bells. This will protect the XLPE cables from abrasion during installation of the cables. These take – off structures are connections between the UG underground distribution cables and the existing 13.2kV OHL overhead distribution lines. This take-off pole structure with its associated accessories to be supplied by APECO.
7. A 3-phase, gang-operated Load break disconnect switch rated 630 Amps, 21 kAIC should be provided on the pole structure with a surge arrester installed and connected

to each respective 15kV XLPE cable with cable clamp on the XLPE cable. Whenever, maintenance or fault occurs on the UG underground circuit we can isolate the

8. A fault indicator is installed clamped on each XLPE cable near the end of cable elbow connectors of the 15kV UGD switchgear DS disconnect switch. These cable fault indicators are an essential part of the underground distribution network. Whenever a fault on the XLPE cable occurs, the cable fault indicator will indicate the fault, thereby providing which cable circuit has the defect fault. In this way, we could isolate the particular circuit in between the UGD's switchgear by opening the DS and at the other end of the healthy UG underground circuit we could close the DS of the UGD switchgear and re-energizing the healthy circuit, thus eliminating the fault and re-energizing back the healthy circuit.
9. The 15kV UG underground distribution system is designed to be a loop circuit provided at each respective road network. This will provide advantage in the selectivity of the circuit during fault conditions.
10. A CFI cable fault indicator device are provided at all RMU incoming and outgoing circuit terminals of the 3 phase switchgear terminals. This will indicate where the particular fault occurs.
11. For each 15kV Riser take-off XLPE cable to be terminated to an OHL overhead distribution line, termination kits of outdoor type (either heat shrink or cold shrink type) should be installed and each ends to be connected to a DS disconnect switch gang operated with manual control rods installed on a steel pole. A surge arresters are provide for each of the 15kV single core cable for cable protection.
12. For each of the UGD underground distribution switchgear provide four (4) ground rods and connect them with the steel wire Aluminum clad steel wire type wire and interconnected to all the four ground rods and continuous ground wire connection to the neutral ground wire of the 15kV underground distribution network.
13. All 15kV UGD switchgear should be installed on a foundation pad with housing made of Aluminum frame and sheet cover or maybe made of CHB concrete blocks on its side while the access door panels shall be made of Aluminum sheet with door frame and with pad-lockable door handles.
14. The roof shall be made of Aluminum sheet with frame for all weather housing for the UGD switchgear. The whole roof frame and cover with two door louvered Aluminum panel doors shall be supplied and installed for this UGD switchgear housing. The panel door shall be pad-lockable type for authorized personnel access only.
15. A two (2) pairs of Rubber gloves with leather working gloves rated 30kV insulation shall be supplied to the Client as part of the operations and maintenance work activity.

A two (2) sets of all-grip (shot-gun) insulated hot stick rated 30kV is required for the switching and maintenance of pad mount transformers and UGD switchgears. All switching operations and maintenance, troubleshooting work activity should wear the proper PPE.

16. A suitable quantity of spares for the dead-end termination kits, mid span joint sleeve, Elbow connector dead-front type for 85mm<sup>2</sup> wire size should be provided at least 1 set (3 pieces) for each type of material.
17. No cable splices such as T-tap connections of the 15kV XLPE cable shall be undertaken inside manholes. This is not allowed, these are weak point joints. And is susceptible to water entry that will cause phase to ground fault.
18. All construction works for the underground distribution system shall be supervised by a Registered Electrical engineer and a registered Civil engineer for the civil works. All works are under the supervision of a professional electrical engineer.
19. All works shall be in accordance to Philippine Electrical Code Part I and Part II, and shall be in accordance to National Electrification Administration of the Philippines, the Local Electric Cooperative and LGU local government unit rules and regulations on the construction works.
20. All works shall be in accordance to OSHA and DOLE shall apply all the Safety precautionary measures on all the construction works at all times.
21. All civil works shall be supervised by a Registered Civil Engineer and shall follow strict Building Construction Code of the Philippines and in accordance to OSHA and DOLE regulations shall apply all the Safety precautionary measures on all the construction works at all times.
22. All electrical works shall be supervised by a qualified REE Registered Electrical Engineer including the cable testing and Switchgear testing methods in accordance to IEC and IEEE standards.

### **Project Timeline Schedule and Reports**

Completion of the Works is required within 270 calendar days upon receipt of the Notice to Proceed (NTP). The suppliers shall submit the proposed timeline of the project and status/progress monitoring report weekly to NEA and APECO.

### **Terms of Payments**

Terms of payment will be based on the milestone (agreed upon during contract finalization) as stated on the table below

<b>Scheduled of Payment</b>	<b>Milestone</b>
15%	Contract Signing
15%	25% Project Completion
20%	50% Project Completion
20%	70% Project Completion

20%	100% Project Completion
10%	Retention

## Warranty

In case of permanent structures, such as buildings of types 4 and 5 as classified under the National Building Code of the Philippines and other structures made of steel, iron, or concrete which comply with relevant structural codes (e.g., DPWH Standard Specifications), such as, but not limited to, steel/concrete bridges, flyovers, aircraft movement areas, ports, dams, tunnels, filtration and treatment plants, sewerage systems, power plants, transmission and communication towers, railway system, and other similar permanent structures: **Fifteen (15) years upon project turn-over.**

## Penalties / Liquidated Damages

Failure to comply with the Terms and Conditions of the contract will result in the payment of corresponding penalties/liquidated damages in the amount equal to 1/10 of 1% of the cost of the unperformed portion for every day of delay. Once the cumulative amount of liquidated damages reaches 10% of the amount of contract, NEA shall rescind the contract, without prejudice to other courses of action and remedies open to it.

## Quality Control and Assurance Standards

- a. All electrical equipment and materials to be used for the construction of the project shall be tested and approved of the national and international standards including but not limited to Department of Trade Industry (DTI) Standards, IEEE Standards, ANSI Standards, IEC Standards, NEA Standards, PEC I and II.
- b. All construction works for the underground distribution system shall be supervised by a Registered Electrical engineer and a registered Civil engineer for the civil works. All works are under the supervision of a Professional Electrical Engineer.
- c. All works shall be in accordance to Philippine Electrical Code Part I and Part II, and shall be in accordance to National Electrification Administration of the Philippines, the Local Electric Cooperative and LGU local government unit rules and regulations on the construction works.
- d. All works shall be in accordance to OSHA and DOLE shall apply all the Safety precautionary measures on all the construction works at all times.
- e. All civil works shall be supervised by a Registered Civil Engineer and shall follow strict Building Construction Code of the Philippines and in accordance to OSHA and DOLE regulations shall apply all the Safety precautionary measures on all the construction works at all times.

- f. All electrical works shall be supervised by a qualified REE Registered Electrical Engineer including the cable testing and Switchgear testing methods in accordance to IEC and IEEE standards.

### **Responsibilities of NEA**

- a. Oversee and monitor the progress of the project(s) until its completion;
- b. Confirm and validate the weekly Accomplishment Reports on the progress of the project implementation to be submitted by the contractor;
- c. Conduct final inspection and acceptance of the project(s) together with the APECO and finalized documentary requirements upon project completion and energization;
- d. Conduct the turnover of the project(s) to APECO; and
- e. Institute appropriate actions and/or impose liquidated damages against the contractor for any and all delays incurred during the implementation of the project(s) pursuant to the provisions of this agreement.

### **Responsibilities of the Contractor**

- a. Provide technical supervision, skilled manpower, tools, equipment and suitable highest quality and acceptable standards materials;
- b. Secure all necessary permits, clearances, right-of-way (ROW), and equivalent documents required for the civil works from private entities and relevant government agencies, including but not limited to the Department of Public Works and Highways (DPWH), Local Government Unit (LGU), Department of Environment and Natural Resources (DENR), Philippine Coconut Authority (PCA);
- c. Ensure that the materials and equipment to be delivered, used and installed shall be of the highest quality and passed in the national and international standards including but not limited to Department of Trade Industry (DTI) Standards, IEEE Standards, ANSI Standards, IEC Standards, NEA Standards, PEC I and II;
- d. Secure and submit all bonds, permits, insurances and other requirements necessary in the implementation of the project;
- e. Ensure the over-all security and safety of the equipment, materials and working personnel;
- f. Ensure the copies of all electrical, civil and any related plans, drawings, diagrams, Factory Acceptance Tests, Manuals and Instructions, under this project properly handed to NEA and APECO;
- g. Submit Program of Works and Gantt Chart and ensure proper documentation of all works during the project implementation;

- h. Submit weekly Accomplishment Reports on the progress of the project implementation to NEA and APECO; and
- i. Testing and Commissioning of all the equipment and materials under this project.
- j. Ensure that all equipment and materials under this Project is properly turned-over to end-user. The Contractor shall conduct training to the end-user for operation and maintenance.

**List of Special Equipment Required**

1	Backhoe Long Arm 0.5 cu.m	2.00
2	Hydraulic Concrete Rock Breaker	1.00
3	Telescoping Boom truck 5 Tonner	1.00
4	Heavy Duty Air Compressor w/ Jackhammer/ Jacklegs	2.00
5	Road Roller Vibro Compactor	1.00
6	Pick up Truck 4x2 or 4x4	2.00
7	Generator Set atleast 30Kva	2.00
8	Winch Pulling Machine	2.00
9	Concrete Vibrator	2.00
10	One Bagger Mixer	2.00
11	Welding Machine 300Amp	2.00
12	OxyAcetylene gas welding and cutting outfit	2.00
13	Electric Rebar Bending Machine	1.00
14	High-Pressure Power Washer	2.00
15	Water pump ( Electrical and Mechanical )	4.00
16	Tamping Rammer	1.00

**List of Key Personnel Required**

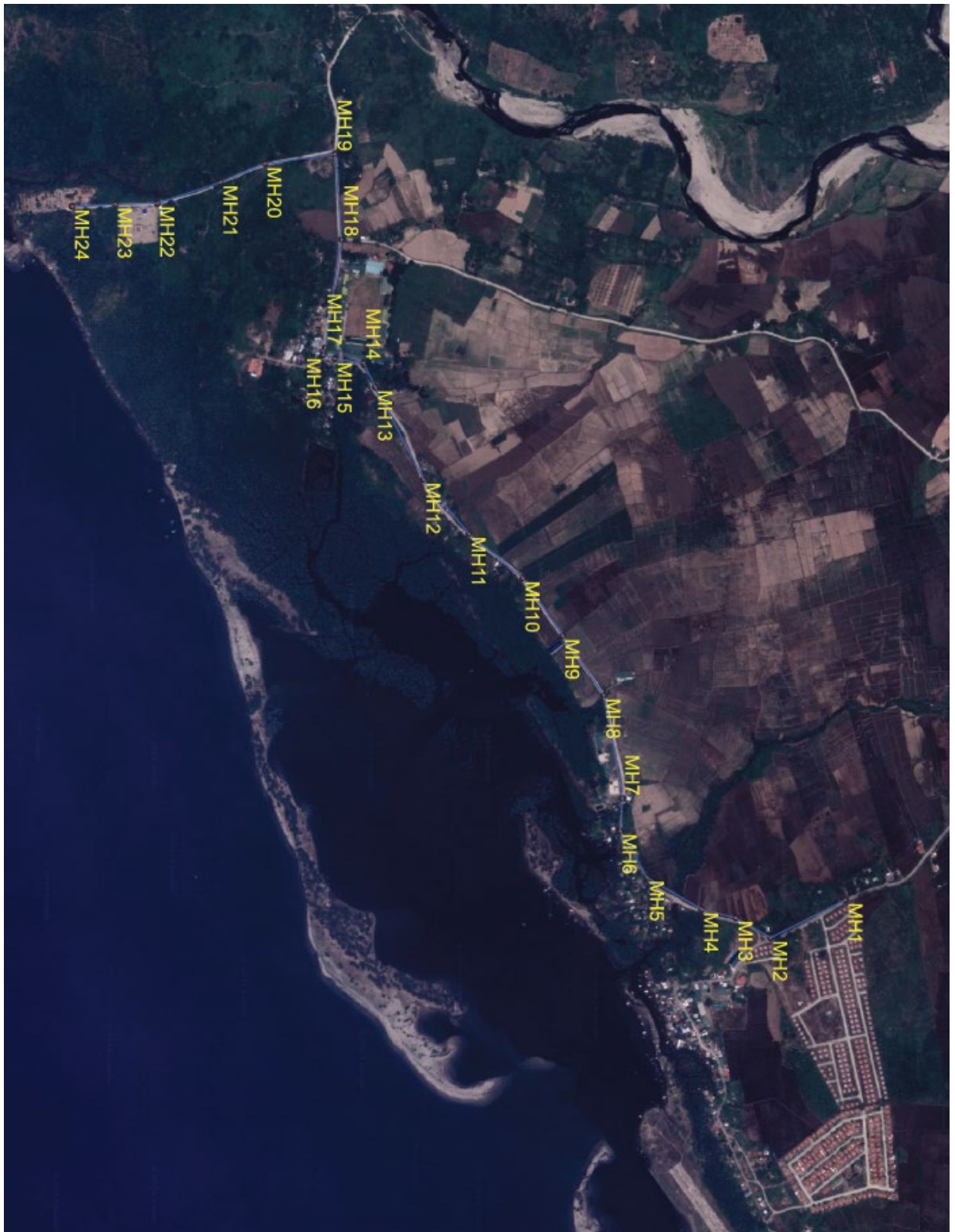
1	Project Manager Electrical (PEE) 10 years Experience	1
2	Project Manager Civil (PCE) 10 years Experience	1
3	QA/QC Inspector Electrical 5 years Experience	1
4	QA/QC Inspector Civil 5 years Experience	1
5	Civil Supervisor 5 years Experience	1
6	Electrical Supervisor Engineer 5 years Experience	1
7	Safety Officer 1 year Experience SO3	3

# Section VII. Drawings



Figure 1 - Land Use Development





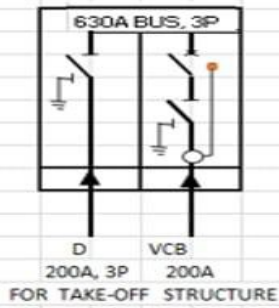
**Figure 2. APECO Underground Power Distribution Line Phase 3**



**Figure 3. APECO Underground Power Distribution Line Phase 4**

**SWITCHGEAR CONFIGURATIONS:**

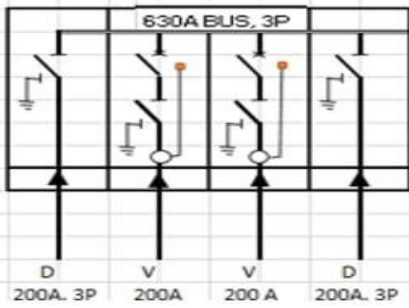
**TYPE - DV UGD SWITCHGEAR**



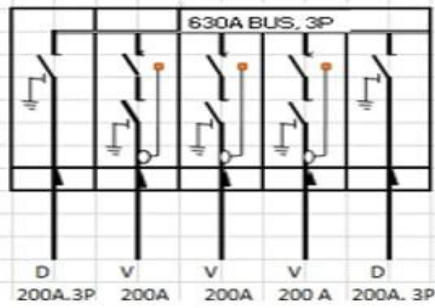
**LEGEND**  
 D - DS - CABLE WITH DISCONNECT SWITCH, WITH EARTH SWITCH  
 V - VCB - CIRCUIT BREAKER WITH DISCONNECT SWITCH WITH RELAY PROTECTION, 50/51

COMPLETE WITH Dead-Front terminal bushings for 85mm<sup>2</sup> XLPE 15kV Cable connection for each Feeder compartment.

**TYPE - DVVD UGD SWITCHGEAR**



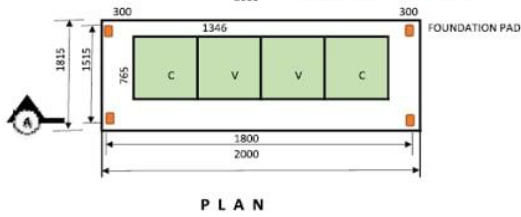
**TYPE - DVVVD UGD SWITCHGEAR**



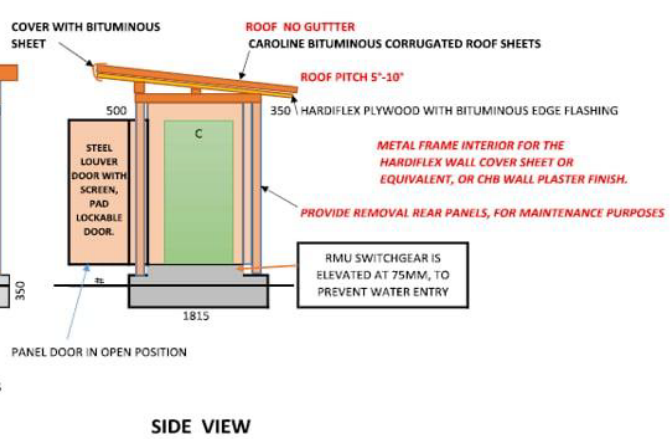
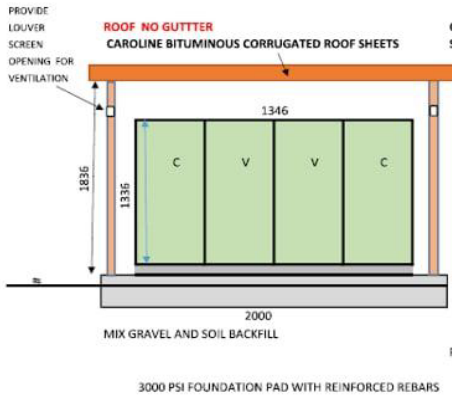
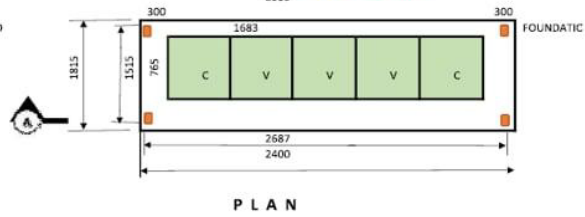
**Figure 4. Switchgear Configuration**

**FOUNDATION PAD DETAILS**

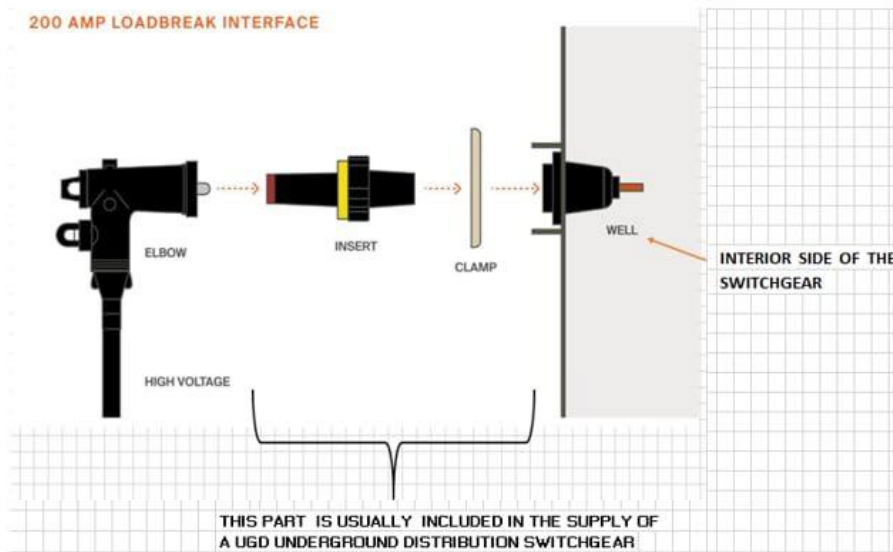
NOTE:  
 1. ALL DIMENSIONS ARE IN MILLIMETERS UNLESS OTHERWISE NOTED.  
 2. THIS DRAWING PLAN & SECTION - A IS FOR **C V V C RMU TYPE SWITCHGEAR**.



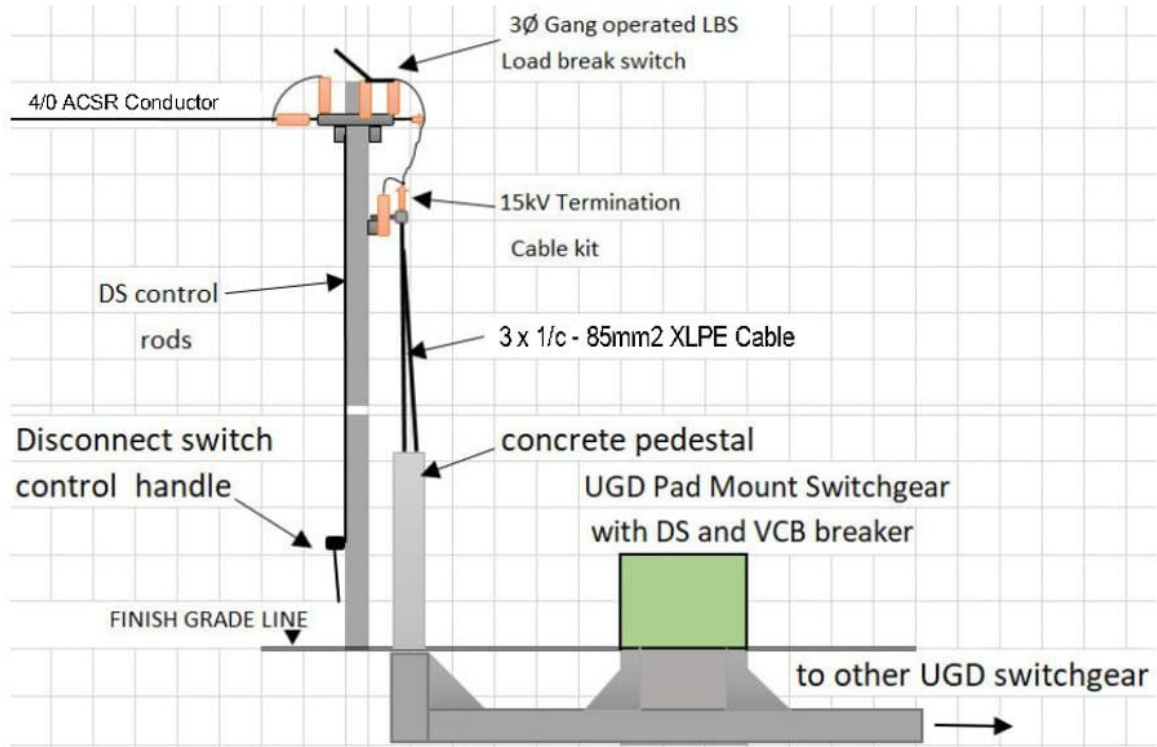
NOTE:  
 1. ALL DIMENSIONS ARE IN MILLIMETERS UNLESS OTHERWISE NOTED.  
 2. THIS DRAWING PLAN & SECTION - A IS FOR **C V V V C RMU TYPE SWITCHGEAR**.



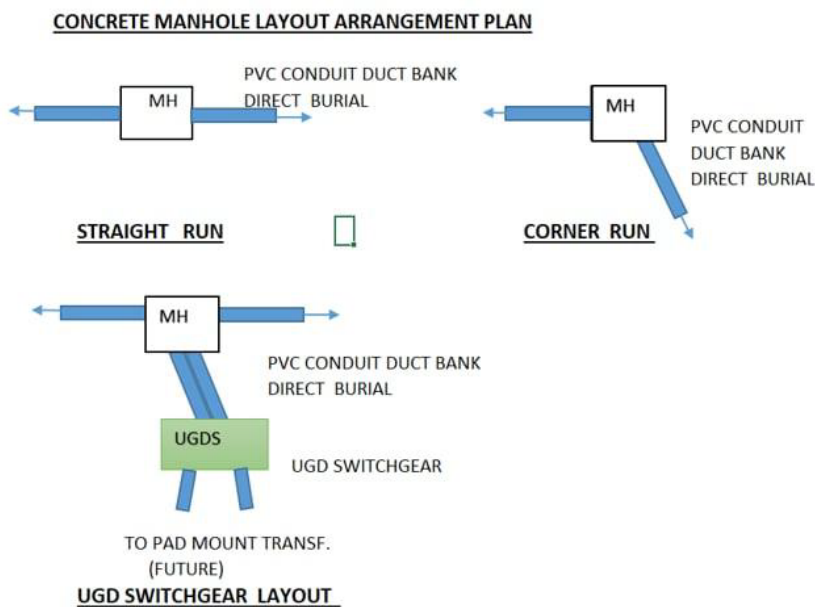
**Figure 5. Plan and Sections views of the Padmount UGD Switchgear Housing**



**Figure 6. PRIMARY MV, SWITCHGEAR TERMINAL BUSHING**

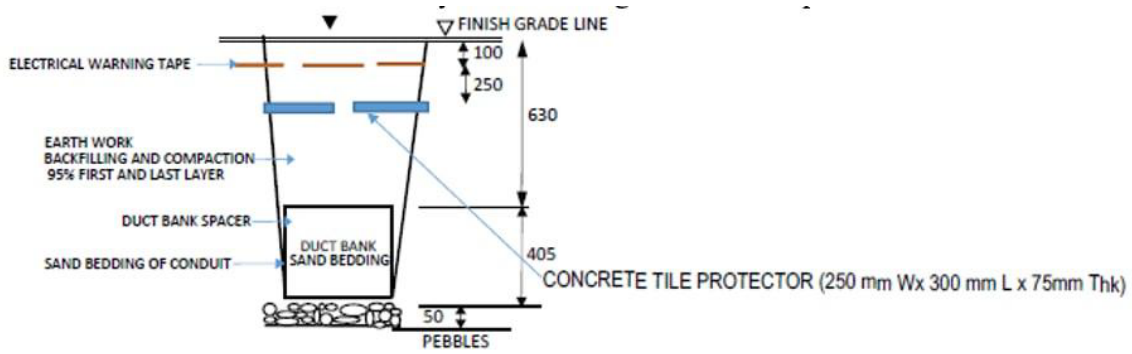


**Figure 7. Take-off Structure**



**Figure 8**

Figure 8 above shows the underground concrete manholes and duct bank arrangement at straight run, corner runs, and with UFD switchgear connections.



DETAILS OF DUCT BANK EXCAVATION  
N T S

Figure 9

Figure 9 above shows the section view of the underground duct bank with the 4 – 110 mm dia. uPVC conduits arrange in Quad formation.

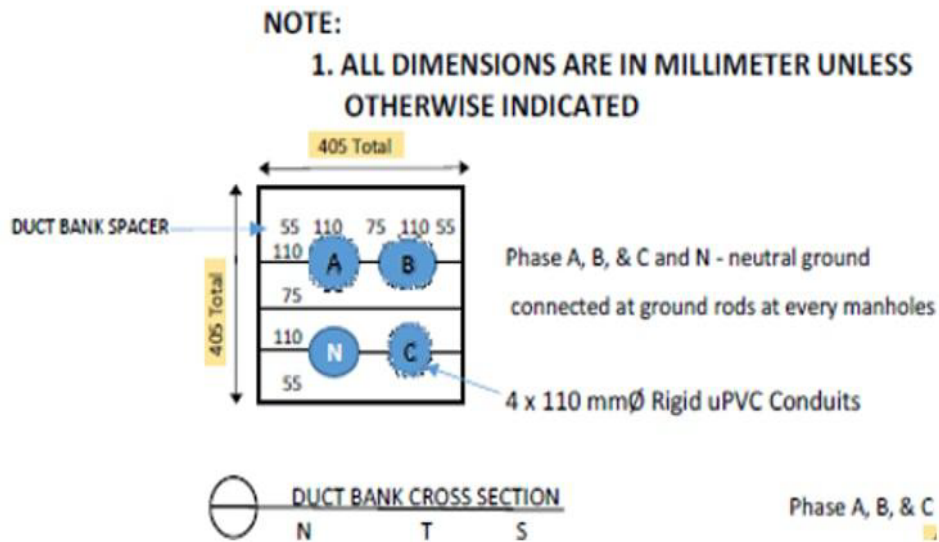
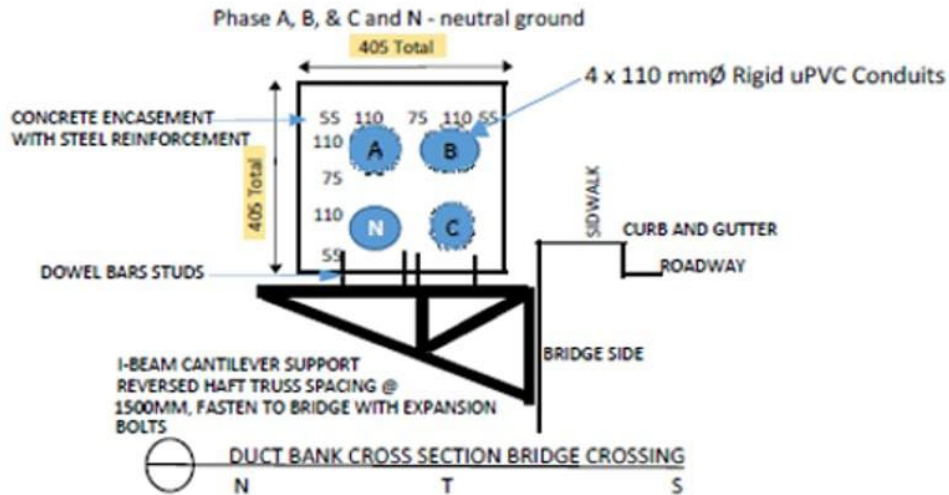


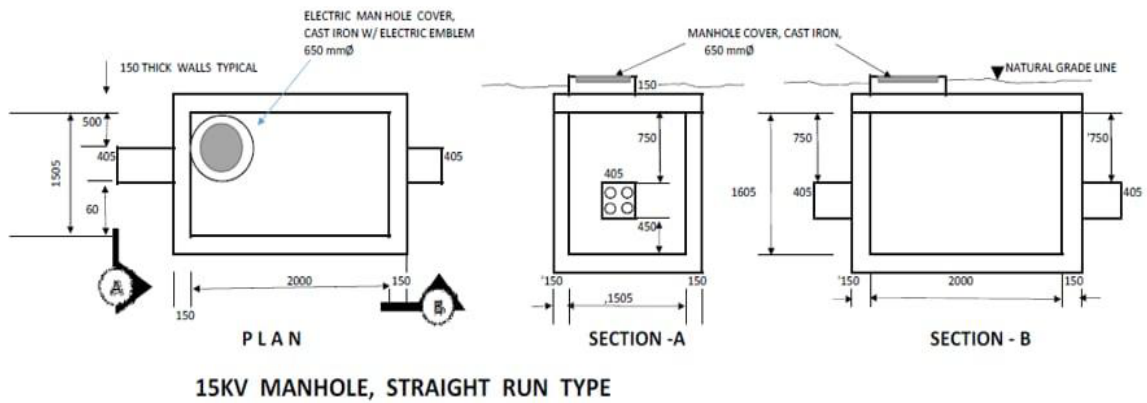
Figure 10

Figure 10 above shows the Quad arrangement of the underground duct bank with the 4 – 110 mm dia. uPVC conduits arrangement in Quad formation. Please note the 3 – 15kV XLPE Phasing, phase A, B and Phase C, while the N refers for the Neutral Line wire composed of 3/8" dia. Alumoweld clad steel wire which are connected to ground at each manholes.

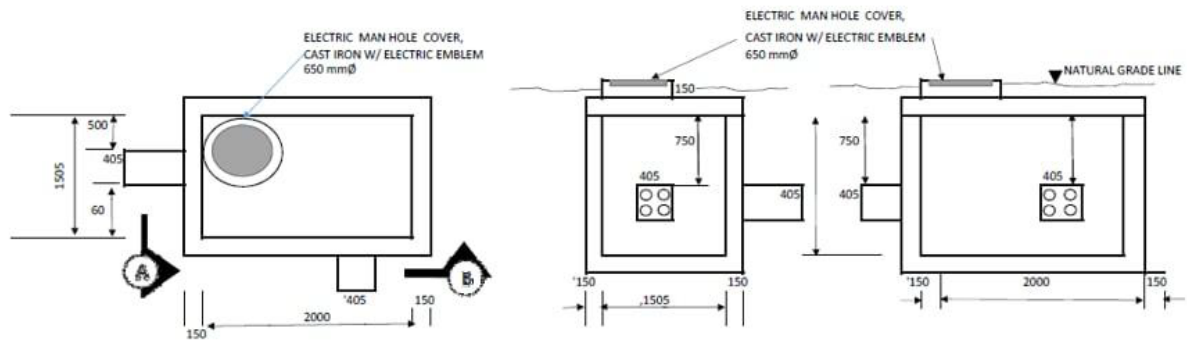


**Figure 11**

Figure 11, above shows the construction of the section view of the duct bank run along the length of the bridge. It is supported by steel angles at every 1000mm distance. The duct bank maybe enclosed in concrete or the uPVC conduits are clamped in Quad formation.



**Figure 12. STRAIGHT RUN TYPE**



15KV MANHOLE, CORNER RUN TYPE

Figure 13. CORNER RUN TYPE

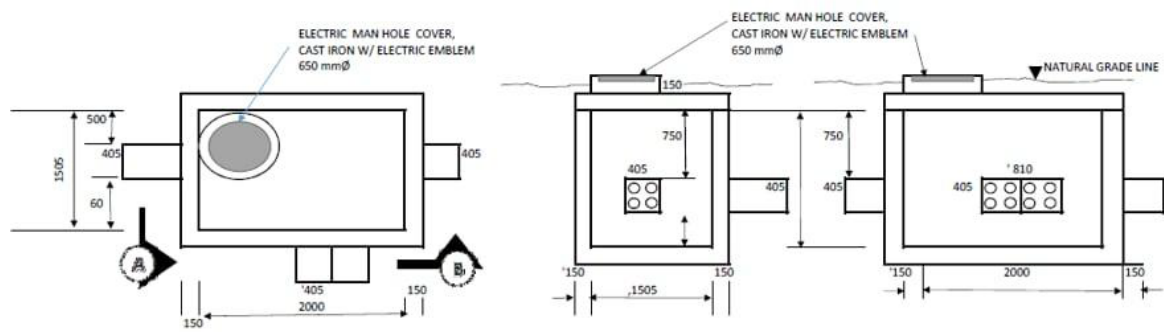
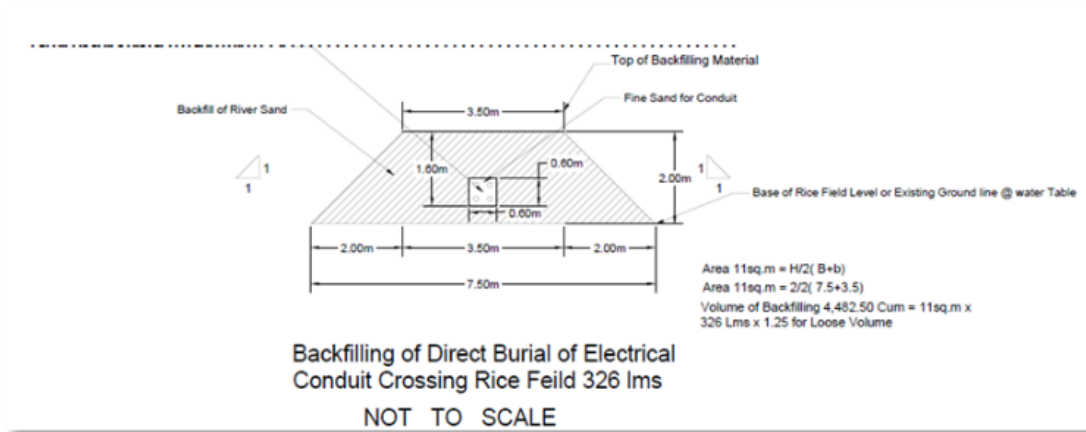


Figure 14. TEE RUN TYPE (design specifically for connection to a Switchgear)





**Figure 15. Underground Duct Bank Design for Crossing Rice Fields in Phase 4**

## *Section VIII. Bill of Quantities*

PROJECT TITLE: CONSTRUCTION OF UNDERGROUND POWERLINES IN APECO PHASE 3  
 LOCATION: BRGY. ESTEVES, CASIGURAN, AURORA

Item No.	Work Item	Unit	Quantity	Unit Cost			Total	Derived Amount			Sub Amount	Amount
				Materials	Labor	Equipment	Unit Cost	Materials	Labor	Equipment		
I.	<b>GENERAL PRELIMINARIES</b>											
1	Mobilization / Demobilization	Lot	1									
2	Temporary Facilities / Field Office and Warehouse	Lot	1									
3	Temporary Water and Power Supply including required deposits	Lot	1									
4	Temporary Telecommunications including internet connection and services	Lot	1									
5	Materials handling and lifting	Lot	1									
6	Testing of Materials (RMC, Rebars, CHB)	Lot	1									

7	Sanitation and Disposal	Lot	1									
8	Survey Works											
	a.) Line and Grade	Lot	1									
9	Supervision and Management	Lot	1									
10	Design eng'g. works item with Electl. & civil design engg	Lot	1									
11	Testing and commissioning for Phase 3, South Side APECO	Lot	1									
12	Relay Protection coordination for UG Switch gears	Lot	1									
13	Supply of a pair of 30kV Rubber gloves with working leather gloves and 1 - Hot stick grip all rated 36 kV (8 ft. Length) use for operating the UGD switchgears	Lot	1									
<b>SUBTOTAL I - General Preliminaries</b>												
II	<b>UG UNDERGROUND DIST. SYSTEM, 3Ø, 13.2KV, ALONG EXISTING ROADWAY, PHASE - 3, SOUTH SIDE</b>											

A	<b><u>CIVIL WORKS ON UG DISTRIBUTION</u></b>											
A.1	<b>MANHOLES, STRAIGHT RUN TYPE</b>	sets	15.00									
a	Excavation	cu. m.	17.87									
b	Lean concrete 50 mm thick	cu. m.	0.40									
c	Form works	sq. m.	29.20									
d	Reinforcing bars installation	kgs	399.26									
e	Install PVC Conduit accessories, End Bell and 8 pcs. 110mmØ x 400 mm L RIGID PVC conduit	sets	8.00									
f	Concrete 3000 psi	cu. m.	2.91									
g	Back Fill & restoration of surroundings	cu. m.	2.77									

h	Excess Excavated materials for Disposal	cu. m.	15.11									
i	Manhole Cover w/ Electric Emblem (Cast iron)	sets	1.00									
j	Galvanized Steel Manhole Ladder Rungs	no.	5.00									
<b>A.2</b>	<b>MANHOLES, TEE- RUN TYPE</b>	sets	2.00									
a	Excavation	cu. m.	17.87									
b	Lean concrete 50 mm thick	cu. m.	0.40									
c	Form works	sq. m.	29.20									
d	Reinforcing bars installation	kgs	399.26									
e	Install PVC Conduit accessories, End Bell and 16 pcs. 110mmØ x 400 mm L RIGID PVC conduit	sets	16.00									
f	Concrete 3000 psi	cu. m.	2.91									

g	Back Fill & restoration of surroundings	cu. m.	2.77									
h	Excess Excavated materials for Disposal	cu. m.	15.11									
i	Manhole Cover w/ Electric Emblem (Cast iron)	no.	1.00									
j	Galvanized Steel Manhole Ladder Rungs	no.	5.00									
<b>A.3</b>	<b>MANHOLES, CORNER RUN TYPE</b>	sets	7.00									
a	Excavation	cu. m.	17.87									
b	Leveling concrete 50 mm thick	cu. m.	0.40									
c	Form works	sq. m.	29.20									
d	Reinforcing bars installation	kgs	399.26									
e	Install PVC Conduit accessories, End Bell and 8 pcs. 110mmØ x 400 mm L RIGID PVC conduit	sets	8.00									

f	Concrete 3000 psi	cu. m.	2.91									
g	Back Fill & restoration of surroundings	cu. m.	2.77									
h	Excess Excavated materials for Disposal	cu. m.	15.11									
i	Manhole Cover w/ Electric Emblem (Cast iron)	no.	1.00									
j	Galvanized Steel Manhole Ladder Rungs	no.	5.00									
<b>A.4</b>	<b>RMU RING MAIN UNIT SWITCHGEAR, 2DS + 3CB TYPE FOUNDATION WITH SWITCHGEAR HOUSING</b>	sets	4.00									
a	RMU Pad foundation Excavation	cu. m.	2.10									
b	Form works	sqm	3.18									
s	Reinforcing bars installation & accessories	kg.	306.00									
d	Concrete 3000 psi	cu. m.	1.74									



e	Back Fill & restoration of surroundings	cu. m.	0.36									
f	Install PVC Conduit accessories, End Bell and 4 pcs. 110mmØ x 400 mm L RIGID PVC conduit	sets	75.00									
g	RMU Ring Main Unit Switchgear Housing 2.7 x 1.8	sets	1.00									
<b>A.5</b>	<b>DUCT BANK, DIRECT BURIAL WITH 4- 110 mmØ PVC CONDUIT</b>	Lm	2,705.00									
a	Excavation works	cu. m.	1,215.76									
b	Duct Bank Sand Bedding	cu. m.	1,147.46									
c	Install RIGID PVC Conduits 4 pcs. 110mmØ x 3.0 m per duct bank	pcs.	3,606.67									
d	Construct duct bank concrete spacer	set	1,803.33									
e	Construct Tile Protector (250 mm W x 300mm L x 75mm thick), including form works & rebars	pcs.	14,607.0 0									
f	Install Warning tape - 300m per roll	roll	10.82									

g	Backfill ordinary soil	cu. m.	860.60									
h	Excess Excavated materials for Disposal	cu. m.	355.17									
<b>A.6</b>	<b>ROAD CROSSING DUCT BANK, EMBEDDED IN CONCRETE WITH 4- 110 mmØ PVC CONDUIT</b>	Lm	8.00									
a	Excavation works	cu. m.	3.60									
b	Duct Bank Sand Bedding	cu. m.	3.39									
c	Install RIGID PVC Conduits 4 pcs. 110mmØ x 3.0 m per duct bank	pcs.	10.67									
d	Construct duct bank concrete spacer	set	5.33									
e	Construct Tile Protector (250 mm W x 300mm L x 75mm thick), including form works & rebars	pcs.	43.20									
f	Install Warning tape - 300m per roll	roll	0.03									
g	Backfill ordinary soil	cu. m.	2.55									

h	Excess Excavated materials for Disposal	cu. m.	1.05									
i	Demolition of existing roadway for the new duct bank crossing including disposal	cu. m.	0.97									
j	Restoration works on excavated concrete roadway	cu. m.	0.97									
<b>A.7</b>	<b>ELEVATED DUCT BANK ON BRIDGE CROSSING 4-110 mmØ PVC CONDUIT</b>	Lm	12.00									
a	Form Works	sqm	14.58									
b	Install reinforcing bars	kg	100.90									
c	Pour Concrete Duct Bank 3000 psi	cu. m.	1.51									
d	Install RIGID PVC Conduits 4 pcs. 110mmØ x 3.0 m per duct bank	pcs.	16.00									
e	Install steel angle and I-Beam supports for duct bank beside roadway bridge	sets	8.00									
f	Construct duct bank concrete spacer	cu. m.	8.00									

<b>A.8</b>	<b>CONSTRUCT CONCRETE PEDESTAL TAKE-OFF STRUCTURE</b>	sets	1.00									
a	Pedestal (Take-off structure) Excavation	cu. m.	10.75									
b	Form works	sq. m.	5.38									
c	Reinforcing bars installation works	kg.	184.00									
d	Install PVC Conduit accessories, 4 x End Bell fittings	sets	8.00									
e	Install 4 pcs. Rigid PVC Conduits 110mmØ x 3.0 meters including Long Elbow conduits	pcs	4.00									
f	Concrete pour on duct bank	cu. m.	1.95									
g	Back Fill & restoration of surroundings	cu. m.	9.60									
<b>A.9</b>	<b>RMU RING MAIN UNIT SWITCHGEAR, 2DS + 1CB TYPE FOUNDATION WITH SWITCHGEAR HOUSING</b>	sets	2.00									

a	RMU Pad foundation Excavation	cu. m.	1.98									
b	Form works	sqm	3.01									
c	Reinforcing bars installation & accessories	kg.	299.00									
d	Concrete 3000 psi	cu. m.	1.73									
e	Back Fill & restoration of surroundings	cu. m.	22.00									
f	Install PVC Conduit accessories, End Bell and 4 pcs. 110mmØ x 400 mm L RIGID PVC conduit	sets	22.00									
g	RMU Ring Main Unit Switchgear Housing 2.7 x 1.8	sets	1.00									
								<b>Total Materials</b>	<b>Total Labor</b>	<b>Total Equipment</b>		
	<b>SUBTOTAL A - CIVIL WORKS ON UG DISTRIBUTION</b>											
<b>B</b>	<b>ELECTRICAL EQUIPMENT, UNDERGROUND CABLES AND OTHER MATERIALS</b>											

1	RMU Ring Main Unit switchgear, 15kV, 200A, 25kaic with 2 x DS Disconnect switch with Ground switch interlocked, 3 x 200A, VCB breakers, Indoor type IP 55, complete with 50/51 relay protection units each CB breakers, (5 compartments, with separate cable terminal compartments)	sets	4.00									
2	Cable Fault Indicator (CFI)	sets	18.00									
3	SUPPLY OF CABLE MARKERS ALONG UG DUCT BANK ROUTE (concrete monuments vertical engrave with "CAUTION HIGH VOLTAGE CABLE BELOW"	pcs.	91.40									
4	8.7/15(17.5)kV AL/XLPE/CWS/LLDPE 1Cx85SQMM.	lmet er	8,926.50									
5	Dead Front, terminal bushing 15kV, 200A, 25kAIC for 85mm <sup>2</sup> XLPE Cable for RMU switchgear	sets	78.00									
6	Mid-span joint sleeve for 1/c - 85mm <sup>2</sup> XLPE 15kV, weather proof, Outdoor type, Heat Shrink type	sets	18.00									
7	Aluminum-clad Steel wires (19 No. 8 AWG size): 19x3.26mm, OD 16.32mm. ASTM B 416.	lmet ers	2,975.50									
8	Ground wire 100mm <sup>2</sup> Bare copper wire	LM	96.00									
9	Ground rods, 16mm dia. X 3.0 meter, hot dip galvanized finish	pcs.	53.00									
10	Thermit weld mold for ground rod to wire 3/8" Alumoweld complete with Mold holder clamp, flint gun, brush	sets	3.00									
11	Thermit weld powder #200 @ 10 tubes per box	box	15.00									

12	RMU Ring Main Unit switchgear, 15kV, 200A, 25kaic with 2 x DS Disconnect switch with Ground switch interlocked, 1 x 200A, VCB breakers, Indoor type IP 55, complete with 50/51 relay protection units each CB breakers, (5 compartments, with separate cable terminal compartments)	sets	2.00									
13	15 KV Termination kit, with terminal lugs compression type for 85mm <sup>2</sup> XLPE cable Outdoor type, for Take-off structure connection to AURELCO Distribution line	sets	6.00									
	<b>SUBTOTAL B - ELECTRICAL EQUIPMENT, UNDERGROUND CABLES AND OTHER MATERIALS</b>											
	TOTAL II- UG UNDERGROUND DIST. SYSTEM, 3Ø, 13.2KV, EXISTING ROADWAY											
								<b>Total Materials</b>	<b>Total Labor</b>	<b>Total Equipment</b>		

PROJECT TITLE: CONSTRUCTION OF UNDERGROUND POWERLINES IN APECO PHASE 4

LOCATION: BRGY. ESTEVES, CASIGURAN, AURORA

Item No.	Work Item	Unit	Quantity	Unit Cost			Total	Derived Amount			Sub Amount	Amount
				Materials	Labor	Equipment	Unit Cost	Materials	Labor	Equipment		
I.	<b>GENERAL PRELIMINARIES</b>											
1	Mobilization / Demobilization	Lot	1.00									
2	Temporary Facilities / Field Office and Warehouse	Lot	1.00									
3	Temporary Water and Power Supply including required deposits	Lot	1.00									
4	Temporary Telecommunications including internet connection and services	Lot	1.00									
5	Materials handling and lifting	Lot	1.00									
6	Testing of Materials (RMC, Rebars, CHB)	Lot	1.00									
7	Sanitation and Disposal	Lot	1.00									
8	Survey Works											
	a.) Line and Grade	Lot	1.00									
9	Supervision and Management	Lot	1.00									



10	Design eng'g. works item with Electl. & civil design engg	Lot	1.00									
11	Testing and commissioning for Phase 4, South Side APECO	Lot	1.00									
12	Relay Protection coordination for UG Switch gears	Lot	1.00									
13	Supply of a pair of 30kV Rubber gloves with working leather gloves and 1 - Hot stick grip all rated 36 kV (8 ft. Length) use for operating the UGD switchgears	Lot	1.00									
	<b>SUBTOTAL I - General Preliminaries</b>											
II	<b>UG UNDERGROUND DIST. SYSTEM, 3Ø, 13.2KV, ALONG EXISTING ROADWAY</b>											
A	<b><u>CIVIL WORKS ON UG DISTRIBUTION</u></b>											
A.1	<b>MANHOLES, STRAIGHT RUN TYPE</b>	<b>sets</b>	<b>41.00</b>									
a	Excavation	cu. m.	17.87									

b	Lean concrete 50 mm thick	cu. m.	0.40									
c	Form works	sq. m.	29.20									
d	Reinforcing bars installation	kgs	399.26									
e	Install PVC Conduit accessories, End Bell and 8 pcs. 110mmØ x 400 mm L RIGID PVC conduit	sets	8.00									
f	Concrete 3000 psi	cu. m.	2.91									
g	Back Fill & restoration of surroundings	cu. m.	2.77									
h	Excess Excavated materials for Disposal	cu. m.	15.11									
i	Manhole Cover w/ Electric Emblem (Cast iron)	no.	1.00									
j	Galvanized Steel Manhole Ladder Rungs	no.	5.00									
<b>A.2</b>	<b>MANHOLES, TEE- RUN TYPE</b>	<b>sets</b>	<b>3.00</b>									
a	Excavation	cu. m.	17.87									
b	Lean concrete 50 mm thick	cu. m.	0.40									
c	Form works	sq. m.	29.20									

d	Reinforcing bars installation	kgs	399.26									
e	Install PVC Conduit accessories, End Bell and 16 pcs. 110mmØ x 400 mm L RIGID PVC conduit	sets	16.00									
f	Concrete 3000 psi	cu. m.	2.91									
g	Back Fill & restoration of surroundings	cu. m.	2.77									
h	Excess Excavated materials for Disposal	cu. m.	15.11									
i	Manhole Cover w/ Electric Emblem (Cast iron)	no.	1.00									
j	Galvanized Steel Manhole Ladder Rungs	no.	5.00									
<b>A.3</b>	<b>MANHOLES, CORNER RUN TYPE</b>	<b>sets</b>	<b>12.00</b>									
a	Excavation	cu. m.	17.87									
b	Leveling concrete 50 mm thick	cu. m.	0.40									
c	Form works	sq. m.	29.20									
d	Reinforcing bars installation	kgs	399.26									
e	Install PVC Conduit accessories, End Bell and 8 pcs. 110mmØ x 400 mm L RIGID PVC conduit	sets	8.00									

f	Concrete 3000 psi	cu. m.	2.91									
g	Back Fill & restoration of surroundings	cu. m.	2.77									
h	Excess Excavated materials for Disposal	cu. m.	15.11									
i	Manhole Cover w/ Electric Emblem (Cast iron)	no.	1.00									
j	Galvanized Steel Manhole Ladder Rungs	no.	5.00									
<b>A.4</b>	<b>RMU RING MAIN UNIT SWITCHGEAR, 2DS + 3CB TYPE FOUNDATION WITH SWITCHGEAR HOUSING</b>	<b>sets</b>	<b>5.00</b>									
a	RMU Pad foundation Excavation	cu. m.	2.10									
b	Form works	sqm	3.18									
c	Reinforcing bars installation & accessories	kg.	306.00									
d	Concrete 3000 psi	cu. m.	1.74									
e	Back Fill & restoration of surroundings	cu. m.	0.36									
f	Install PVC Conduit accessories, End Bell and 4 pcs. 110mmØ x 400 mm L RIGID PVC conduit	sets	75.00									
g	RMU Ring Main Unit Switchgear Housing 2.7 x 1.8	sets	1.00									

<b>A.5</b>	<b>DUCT BANK, DIRECT BURIAL WITH 4- 110 mmØ PVC CONDUIT</b>	<b>Lm</b>	<b>4,265.00</b>									
a	Excavation works	cu. m.	1,916.90									
b	Duct Bank Sand Bedding	cu. m.	1,809.21									
c	Install RIGID PVC Conduits 4 pcs. 110mmØ x 3.0 m per duct bank	pcs.	5,686.67									
d	Construct duct bank concrete spacer	set	2,843.33									
e	Construct Tile Protector (250 mm W x 300mm L x 75mm thick), including form works & rebars	pcs.	23,031.0 0									
f	Install Warning tape - 300m per roll	roll	17.06									
g	Backfill ordinary soil	cu. m.	1,356.91									
h	Excess Excavated materials for Disposal	cu. m.	559.99									
<b>A.6</b>	<b>ROAD CROSSING DUCT BANK, EMBEDDED IN CONCRETE WITH 4- 110 mmØ PVC CONDUIT</b>	<b>Lm</b>	<b>36.00</b>									
a	Excavation works	cu. m.	16.18									

b	Duct Bank Sand Bedding	cu. m.	15.27									
c	Install RIGID PVC Conduits 4 pcs. 110mmØ x 3.0 m per duct bank	pcs.	48.00									
d	Construct duct bank concrete spacer	set	24.00									
e	Construct Tile Protector (250 mm W x 300mm L x 75mm thick), including form works & rebars	pcs.	194.40									
f	Install Warning tape - 300m per roll	roll	0.14									
g	Backfill ordinary soil	cu. m.	11.45									
h	Excess Excavated materials for Disposal	cu. m.	4.73									
i	Demolition of existing roadway for the new duct bank crossing including disposal	cu. m.	4.37									
j	Restoration works on excavated concrete roadway	cu. m.	4.37									
<b>A.7</b>	<b>ELEVATED DUCT BANK ON BRIDGE CROSSING, 4-110 mmØ mmØ PVC CONDUIT</b>	<b>Lm</b>	<b>50.00</b>									
a	Form Works	sqm	60.75									
b	Install reinforcing bars	kg	420.41									

c	Pour Concrete Duct Bank 3000 psi	cu. m.	6.30									
d	Install RIGID PVC Conduits 4 pcs. 110mmØ x 3.0 m per duct bank	pcs.	66.67									
e	Install steel angle and I-Beam supports for duct bank beside roadway bridge	sets	33.33									
f	Construct duct bank concrete spacer	cu. m.	33.33									
<b>A.8</b>	<b>CONSTRUCT CONCRETE PEDESTAL TAKE-OFF STRUCTURE</b>	<b>sets</b>	<b>1.00</b>									
a	Pedestal (Take-off structure) Excavation	cu. m.	10.75									
b	Form works	sq. m.	5.38									
c	Reinforcing bars installation works	kg.	184.00									
d	Install PVC Conduit accessories, 4 x End Bell fittings	sets	8.00									
e	Install 4 pcs. Rigid PVC Conduits 110mmØ x 3.0 meters including Long Elbow conduits	pcs	4.00									
f	Concrete pour on duct bank	cu. m.	1.95									
g	Back Fill & restoration of surroundings	cu. m.	9.60									

<b>A.9</b>	<b>RMU RING MAIN UNIT SWITCHGEAR, 2DS + 1CB TYPE FOUNDATION WITH SWITCHGEAR HOUSING</b>	<b>sets</b>	<b>2.00</b>									
a	RMU Pad foundation Excavation	cu. m.	1.98									
b	Form works	sqm	3.01									
c	Reinforcing bars installation & accessories	kg.	299.00									
d	Concrete 3000 psi	cu. m.	1.73									
e	Back Fill & restoration of surroundings	cu. m.	22.00									
f	Install PVC Conduit accessories, End Bell and 4 pcs. 110mmØ x 400 mm L RIGID PVC conduit	sets	22.00									
g	RMU Ring Main Unit Switchgear Housing 2.7 x 1.8	sets	1.00									
<b>A.10</b>	<b>DUCT BANK, THROUGH RICE FIELD 4- 110 mmØ PVC CONDUIT</b>	<b>LMS</b>	<b>326.00</b>									
a	Backfilling of River Sand Crossing Rice Fields 326 lms	cu. m.	4,482.50									
b	Install RIGID PVC Conduits 4 pcs. 100mmØ x 3.0 m per duct bank	pcs.	434.67									



	<b>SUBTOTAL A - CIVIL WORKS ON UG DISTRIBUTION</b>											
<b>B</b>	<b>ELECTRICAL EQUIPMENT, UNDERGROUND CABLES AND OTHER MATERIALS</b>											
1	8.7/15(17.5)kV AL/XLPE/CWS/LLDPE 1Cx85SQMM.	Lme ters	15,150.3 0									
2	Dead Front, terminal bushing 15kV, 200A, 25kaIC for 60mm <sup>2</sup> XLPE Cable for RMU switchgear	pcs.	93.00									
3	15 KV Termination kit, with terminal lugs compression type for 85mm <sup>2</sup> XLPE cable Outdoor type, for Take-off structure connection to AURELCO Distribution line	sets	6.00									
4	Mid-span joint sleeve for 1/c - 85mm <sup>2</sup> XLPE, weather proof, Outdoor type, Heat Shrink type	pcs.	26.00									
5	RMU Ring Main Unit switchgear, 15kV, 200A, 25kaic with 2 x DS Disconnect switch with Ground switch interlocked, 3 x 200A, VCB breakers, Indoor type IP 55, complete with 50/51 relay protection units each CB breakers, (5 compartments, with separate cable terminal compartments)	sets	5.00									

6	Cable Fault Indicator (CFI)	sets	21.00									
7	Aluminum-clad Steel wires (19 No. 8 AWG size): 19x3.26mm, OD 16.32mm. ASTM B 416.	Lengths	5,050.10									
8	Ground wire 100mm <sup>2</sup> Bare copper wire	LM	112.00									
9	Ground rods, hot-dip galvanized finish 16mmØ x 3.0 meter	pcs.	84.00									
10	Thermit Weld Molds; Wire to Ground rod to 1/C - 19 x 3.26 mm B.Alum. Wire	sets	2.00									
11	Thermit Weld Molds; Wire to Wire to 1/C - 19 x 3.26 mm B.Alum. Wire	sets	2.00									
12	Thermit Weld Powder #200 (10 tubes per box)	box	20.00									
13	Thermit Weld accessories; steel brush, Mold clamp	sets	2.00									
14	SUPPLY OF CABLE MARKERS ALONG UG DUCT BANK ROUTE (concrete monuments vertical engrave with "CAUTION HIGH VOLTAGE CABLE BELOW")	sets	163.00									
15	RMU Ring Main Unit switchgear, 15kV, 200A, 25kaic with 2 x DS Disconnect switch with Ground switch interlocked, 1 x 200A, VCB breakers, Indoor type IP 55, complete with 50/51 relay protection units each CB breakers, (5 compartments, with separate cable terminal compartments)	sets	2.00									

	<b>SUBTOTAL B - ELECTRICAL EQUIPMENT, UNDERGROUND CABLES AND OTHER MATERIALS</b>											
	<b>TOTAL II - UG UNDERGROUND DIST. SYSTEM, 3Ø, 13.2KV, ALONG EXISTING ROADWAY</b>											
								<b>Total Materials</b>	<b>Total Labo r</b>	<b>Total Equipment</b>		
	<b>GRAND TOTAL AMOUNT</b>											

***Section IX. Checklist of Technical and Financial Documents***

# Checklist of Technical and Financial Documents

<b>I. TECHNICAL COMPONENT ENVELOPE</b>	
<i>Class "A" Documents</i>	
<u>Legal Documents</u>	
<input type="checkbox"/>	(a) Valid PhilGEPS Registration Certificate (Platinum Membership) (all pages) in accordance with Section 8.5.2 of the IRR; <ul style="list-style-type: none"> <li>● Registration Certificate from Securities and Exchange Commission (SEC), Department of Trade and Industry (DTI) for sole proprietorship or Cooperative Development Authority (CDA) for cooperatives or its equivalent document, and</li> <li>● Mayor's or Business Permit issued by the city or municipality where the principal place of business of the prospective bidder located, or equivalent document for Exclusive Economic Zones or Areas;</li> <li>● Tax Clearance per E.O. No. 398, s. 2005, as finally reviewed and approved by the Bureau of Internal Revenue (BIR);</li> <li>● Philippine Contractors Accreditation Board (PCAB) license and registration (<i>principal classification in specialty SP-EE (electrical works) with size range of Medium B, License Category A</i>);</li> <li>● Audited Financial Statements, stamped "received" by the BIR or its duly accredited and authorized institutions, for the preceding calendar year</li> </ul>
<u>Technical Documents</u>	
<input type="checkbox"/>	(b) Statement of the prospective bidder of all its ongoing government and private contracts, including contracts awarded but not yet started, if any, whether similar or not similar in nature and complexity to the contract to be bid; <b>and</b>
<input type="checkbox"/>	(c) Statement of the bidder's Single Largest Completed Contract (SLCC) similar to the contract to be bid, except under conditions provided under the rules; <b>and</b>
<input type="checkbox"/>	(d) Special PCAB License in case of Joint Ventures <b>and</b> registration for the type and cost of the contract to be bid; <b>and</b>
<input type="checkbox"/>	(e) Original copy of Bid Security. If in the form of a Surety Bond, submit also a certification issued by the Insurance Commission <b>or</b> original copy of Notarized Bid Securing Declaration; <b>and</b>
	(f) Project Requirements, which shall include the following:
<input type="checkbox"/>	a. Organizational chart for the contract to be bid;
<input type="checkbox"/>	b. List of contractor's key personnel ( <i>e.g.</i> , Project Manager, Project Engineers, Materials Engineers, and Foremen), to be assigned to the contract to be bid, with their complete qualification and experience data;
<input type="checkbox"/>	c. List of contractor's major equipment units, which are owned, leased, and/or under purchase agreements, supported by proof of ownership or certification of availability of equipment from the equipment lessor/vendor for the duration of the project, as the case may be; <b>and</b>
<input type="checkbox"/>	(g) Original duly signed Omnibus Sworn Statement (OSS) <b>and</b> if applicable, Original Notarized Secretary's Certificate in case of a corporation, partnership, or

	cooperative; or Original Special Power of Attorney of all members of the joint venture giving full power and authority to its officer to sign the OSS and do acts to represent the Bidder.
<b><u>Financial Documents</u></b>	
<input type="checkbox"/>	(h) The prospective bidder's computation of Net Financial Contracting Capacity (NFCC). NFCC must be at least equal to the ABC to be bid, calculated as follows: NFCC = [(Current assets minus current liabilities) (15)] minus the value of all outstanding or uncompleted portions of the projects under ongoing contracts, including awarded contracts yet to be started, coinciding with the contract to be bid. ABC: Lot 1- PhP179,450,000.00; Lot 2 – PhP101,850,000.00; Total Lot 1 & Lot 2 – PhP281,300,000.00
<b><u>Class "B" Documents</u></b>	
<input type="checkbox"/>	(i) If applicable, duly signed joint venture agreement (JVA) in accordance with RA No. 4566 and its IRR in case the joint venture is already in existence <u>or</u> duly notarized statements from all the potential joint venture partners stating that they will enter into and abide by the provisions of the JVA in the instance that the bid is successful.
<b>II. FINANCIAL COMPONENT ENVELOPE</b>	
<input type="checkbox"/>	(j) Original of duly signed and accomplished Financial Bid Form; <b><u>and</u></b>
<b><u>Other documentary requirements under RA No. 9184</u></b>	
<input type="checkbox"/>	(k) Original of duly signed Bid Prices in the Bill of Quantities; <b><u>and</u></b>
<input type="checkbox"/>	(l) Duly accomplished Detailed Estimates Form, including a summary sheet indicating the unit prices of construction materials, labor rates, and equipment rentals used in coming up with the Bid; <b><u>and</u></b>
<input type="checkbox"/>	(m) Cash Flow by Quarter.

## ***Section X. Forms***

**Statement of all Ongoing Government and Private Contracts Including  
Contracts Awarded but not yet Started**

*[shall be submitted with the Bid]*

Business Name : \_\_\_\_\_

Business Address : \_\_\_\_\_

Name of Client/Contract Person/Contact Number/Contact Email Address	Date of Contract	Title of the Contract/Name of the Project	Kinds of Goods	Total Amount of Contract	Value of Outstanding Contract	Date of Delivery
<u>Government:</u>						
<u>Private:</u>						

Note: This statement shall be supported with: Notice of Award, Contract, NTP, and other docs, if necessary.

Submitted by : \_\_\_\_\_

(Printed Name and Signature)

Designation : \_\_\_\_\_

Date : \_\_\_\_\_



**Statement of Single Largest Completed Contract which is Similar in Nature**

*[shall be submitted with the Bid]*

Business Name : \_\_\_\_\_

Business Address : \_\_\_\_\_

Name of Client/Contract Person/Contact Number/Contact Email Address	Date of Contract	Title of the Contract/Name of the Project	Kinds of Goods	Amount of Contract	Date of Acceptance	End-User's Acceptance or Official Receipt(s) Issued for the Contract

Note: This statement shall be supported with: Notice of Award, Contract, NTP, and other docs, if necessary.

Submitted by : \_\_\_\_\_

(Printed Name and Signature)

Designation : \_\_\_\_\_

Date : \_\_\_\_\_

## **Bid Securing Declaration Form**

*[shall be submitted with the Bid if bidder opts to provide this form of bid security]*

---

REPUBLIC OF THE PHILIPPINES)  
CITY OF \_\_\_\_\_ ) S.S.

### **BID SECURING DECLARATION**

**Project Identification No.: *[Insert number]***

To: *[Insert name and address of the Procuring Entity]*

I/We, the undersigned, declare that:

1. I/We understand that, according to your conditions, bids must be supported by a Bid Security, which may be in the form of a Bid Securing Declaration.
2. I/We accept that: (a) I/we will be automatically disqualified from bidding for any procurement contract with any procuring entity for a period of two (2) years upon receipt of your Blacklisting Order; and, (b) I/we will pay the applicable fine provided under Section 6 of the Guidelines on the Use of Bid Securing Declaration, within fifteen (15) days from receipt of the written demand by the procuring entity for the commission of acts resulting to the enforcement of the bid securing declaration under Sections 23.1(b), 34.2, 40.1 and 69.1, except 69.1(f), of the IRR of RA No. 9184; without prejudice to other legal action the government may undertake.
3. I/We understand that this Bid Securing Declaration shall cease to be valid on the following circumstances:
  - a. Upon expiration of the bid validity period, or any extension thereof pursuant to your request;
  - b. I am/we are declared ineligible or post-disqualified upon receipt of your notice to such effect, and (i) I/we failed to timely file a request for reconsideration or (ii) I/we filed a waiver to avail of said right; and
  - c. I am/we are declared the bidder with the Lowest Calculated Responsive Bid, and I/we have furnished the performance security and signed the Contract.

IN WITNESS WHEREOF, I/We have hereunto set my/our hand/s this \_\_\_\_ day of *[month]* *[year]* at *[place of execution]*.

*[Insert NAME OF BIDDER OR ITS AUTHORIZED REPRESENTATIVE]*

*[Insert signatory's legal capacity]*

Affiant

**[Jurat]**

*[Format shall be based on the latest Rules on Notarial Practice]*

## Omnibus Sworn Statement (Revised)

*[shall be submitted with the Bid]*

REPUBLIC OF THE PHILIPPINES )  
CITY/MUNICIPALITY OF \_\_\_\_\_ ) S.S.

### AFFIDAVIT

I, [Name of Affiant], of legal age, [Civil Status], [Nationality], and residing at [Address of Affiant], after having been duly sworn in accordance with law, do hereby depose and state that:

1. *[Select one, delete the other:]*

*[If a sole proprietorship:]* I am the sole proprietor or authorized representative of [Name of Bidder] with office address at [address of Bidder];

*[If a partnership, corporation, cooperative, or joint venture:]* I am the duly authorized and designated representative of [Name of Bidder] with office address at [address of Bidder];

2. *[Select one, delete the other:]*

*[If a sole proprietorship:]* As the owner and sole proprietor, or authorized representative of [Name of Bidder], I have full power and authority to do, execute and perform any and all acts necessary to participate, submit the bid, and to sign and execute the ensuing contract for [Name of the Project] of the [Name of the Procuring Entity], as shown in the attached duly notarized Special Power of Attorney;

*[If a partnership, corporation, cooperative, or joint venture:]* I am granted full power and authority to do, execute and perform any and all acts necessary to participate, submit the bid, and to sign and execute the ensuing contract for [Name of the Project] of the [Name of the Procuring Entity], as shown in the attached [state title of attached document showing proof of authorization (e.g., duly notarized Secretary's Certificate, Board/Partnership Resolution, or Special Power of Attorney, whichever is applicable)];

3. [Name of Bidder] is not "blacklisted" or barred from bidding by the Government of the Philippines or any of its agencies, offices, corporations, or Local Government Units, foreign government/foreign or international financing institution whose blacklisting rules have been recognized by the Government Procurement Policy Board, **by itself or by relation, membership, association, affiliation, or controlling interest with another blacklisted person or entity as defined and provided for in the Uniform Guidelines on Blacklisting;**

4. Each of the documents submitted in satisfaction of the bidding requirements is an authentic copy of the original, complete, and all statements and information provided therein are true and correct;

5. [Name of Bidder] is authorizing the Head of the Procuring Entity or its duly authorized representative(s) to verify all the documents submitted;

6. *[Select one, delete the rest:]*

*[If a sole proprietorship:]* The owner or sole proprietor is not related to the Head of the Procuring Entity, Procurement Agent if engaged, members of the Bids and Awards Committee (BAC), the Technical Working Group, and the BAC Secretariat, the head of the Project Management Office or the end-user unit, and the project consultants by consanguinity or affinity up to the third civil degree;

*[If a partnership or cooperative:]* None of the officers and members of *[Name of Bidder]* is related to the Head of the Procuring Entity, Procurement Agent if engaged, members of the Bids and Awards Committee (BAC), the Technical Working Group, and the BAC Secretariat, the head of the Project Management Office or the end-user unit, and the project consultants by consanguinity or affinity up to the third civil degree;

*[If a corporation or joint venture:]* None of the officers, directors, and controlling stockholders of *[Name of Bidder]* is related to the Head of the Procuring Entity, Procurement Agent if engaged, members of the Bids and Awards Committee (BAC), the Technical Working Group, and the BAC Secretariat, the head of the Project Management Office or the end-user unit, and the project consultants by consanguinity or affinity up to the third civil degree;

7. *[Name of Bidder]* complies with existing labor laws and standards; and
8. *[Name of Bidder]* is aware of and has undertaken the responsibilities as a Bidder in compliance with the Philippine Bidding Documents, which includes:
  - a. Carefully examining all of the Bidding Documents;
  - b. Acknowledging all conditions, local or otherwise, affecting the implementation of the Contract;
  - c. Making an estimate of the facilities available and needed for the contract to be bid, if any; and
  - d. Inquiring or securing Supplemental/Bid Bulletin(s) issued for the *[Name of the Project]*.
9. *[Name of Bidder]* did not give or pay directly or indirectly, any commission, amount, fee, or any form of consideration, pecuniary or otherwise, to any person or official, personnel or representative of the government in relation to any procurement project or activity.
10. **In case advance payment was made or given, failure to perform or deliver any of the obligations and undertakings in the contract shall be sufficient grounds to constitute criminal liability for Swindling (Estafa) or the commission of fraud with unfaithfulness or abuse of confidence through misappropriating or converting any payment received by a person or entity under an obligation involving the duty to deliver certain goods or services, to the prejudice of the public and the government of the Philippines pursuant to Article 315 of Act No. 3815 s. 1930, as amended, or the Revised Penal Code.**

IN WITNESS WHEREOF, I have hereunto set my hand this \_\_\_ day of \_\_\_, 20\_\_ at \_\_\_\_\_, Philippines.

*[Insert NAME OF BIDDER OR ITS AUTHORIZED REPRESENTATIVE]*

*[Insert signatory's legal capacity]*

Affiant

***[Jurat]***

*[Format shall be based on the latest Rules on Notarial Practice]*

**Bid Form for the Procurement of Infrastructure Projects**

## **BID FORM**

Date : \_\_\_\_\_

Project Identification No. : \_\_\_\_\_

To: *[name and address of Procuring Entity]*

Having examined the Philippine Bidding Documents (PBDs) including the Supplemental or Bid Bulletin Numbers *[insert numbers]*, the receipt of which is hereby duly acknowledged, we, the undersigned, declare that:

- a. We have no reservation to the PBDs, including the Supplemental or Bid Bulletins, for the Procurement Project: *[insert name of contract]*;
- b. We offer to execute the Works for this Contract in accordance with the PBDs;
- c. The total price of our Bid in words and figures, excluding any discounts offered below is: *[insert information]*;
- d. The discounts offered and the methodology for their application are: *[insert information]*;
- e. The total bid price includes the cost of all taxes, such as, but not limited to: *[specify the applicable taxes, e.g. (i) value added tax (VAT), (ii) income tax, (iii) local taxes, and (iv) other fiscal levies and duties]*, which are itemized herein and reflected in the detailed estimates,
- f. Our Bid shall be valid within the a period stated in the PBDs, and it shall remain binding upon us at any time before the expiration of that period;
- g. If our Bid is accepted, we commit to obtain a Performance Security in the amount of *[insert percentage amount]* percent of the Contract Price for the due performance of the Contract, or a Performance Securing Declaration in lieu of the the allowable forms of Performance Security, subject to the terms and conditions of issued GPPB guidelines<sup>2</sup> for this purpose;
- h. We are not participating, as Bidders, in more than one Bid in this bidding process, other than alternative offers in accordance with the Bidding Documents;
- i. We understand that this Bid, together with your written acceptance thereof included in your notification of award, shall constitute a binding contract between us, until a formal Contract is prepared and executed; and
- j. We understand that you are not bound to accept the Lowest Calculated Bid or any other Bid that you may receive.
- k. We likewise certify/confirm that the undersigned, is the duly authorized

---

<sup>2</sup> currently based on GPPB Resolution No. 09-2020

representative of the bidder, and granted full power and authority to do, execute and perform any and all acts necessary to participate, submit the bid, and to sign and execute the ensuing contract for the [Name of Project] of the [Name of the Procuring Entity].

1. We acknowledge that failure to sign each and every page of this Bid Form, including the Bill of Quantities, shall be a ground for the rejection of our bid.

Name: \_\_\_\_\_

Legal Capacity: \_\_\_\_\_

Signature: \_\_\_\_\_

Duly authorized to sign the Bid for and behalf of: \_\_\_\_\_

Date: \_\_\_\_\_

## **Contract Agreement Form for the Procurement of Infrastructure Projects (Revised)**

*[not required to be submitted with the Bid, but it shall be submitted within ten (10) days after receiving the  
Notice of Award]*

---

### **CONTRACT AGREEMENT**

THIS AGREEMENT, made this *[insert date]* day of *[insert month]*, *[insert year]* between *[name and address of PROCURING ENTITY]* (hereinafter called the “Entity”) and *[name and address of Contractor]* (hereinafter called the “Contractor”).

WHEREAS, the Entity is desirous that the Contractor execute *[name and identification number of contract]* (hereinafter called “the Works”) and the Entity has accepted the Bid for *[contract price in words and figures in specified currency]* by the Contractor for the execution and completion of such Works and the remedying of any defects therein.

NOW THIS AGREEMENT WITNESSETH AS FOLLOWS:

1. In this Agreement, words and expressions shall have the same meanings as are respectively assigned to them in the Conditions of Contract hereinafter referred to.
2. The following documents as required by the 2016 revised Implementing Rules and Regulations of Republic Act No. 9184 shall be deemed to form and be read and construed as part of this Agreement, *viz.*:
  - a. Philippine Bidding Documents (PBDs);
    - i. Drawings/Plans;
    - ii. Specifications;
    - iii. Bill of Quantities;
    - iv. General and Special Conditions of Contract;
    - v. Supplemental or Bid Bulletins, if any;
  - b. Winning bidder’s bid, including the Eligibility requirements, Technical and Financial Proposals, and all other documents or statements submitted;

Bid form, including all the documents/statements contained in the Bidder’s bidding envelopes, as annexes, and all other documents submitted (*e.g.*, Bidder’s response to request for clarifications on the bid), including corrections to the bid, if any, resulting from the Procuring Entity’s bid evaluation;

- c. Performance Security;
    - d. Notice of Award of Contract and the Bidder’s conforme thereto; and
    - e. Other contract documents that may be required by existing laws and/or the Procuring Entity concerned in the PBDs. **Winning bidder agrees that additional contract documents or information prescribed by the GPPB that are subsequently required for submission after the contract execution, such as the Notice to Proceed, Variation Orders, and Warranty Security, shall likewise form part of the Contract.**
3. In consideration for the sum of *[total contract price in words and figures]* or such other sums as may be ascertained, *[Named of the bidder]* agrees to *[state the object of the contract]* in accordance with his/her/its Bid.
4. The *[Name of the procuring entity]* agrees to pay the above-mentioned sum in accordance with the terms of the Bidding.

IN WITNESS whereof the parties thereto have caused this Agreement to be executed the day and year first before written.

*[Insert Name and Signature]*  
*[Insert Signatory's Legal Capacity]*

*for:*  
*[Insert Procuring Entity]*

*[Insert Name and Signature]*  
*[Insert Signatory's Legal Capacity]*

*for:*  
*[Insert Name of Supplier]*

**Acknowledgment**

*[Format shall be based on the latest Rules on Notarial Practice]*